



504/504-US Operator's Manual

Manual Version 1.4

9/89

**Catalog Number 587
Part No. 40788B001**

COPYRIGHT, CRITICARE SYSTEMS, INC. 1988

CRITICARE SYSTEMS, INC. ("Criticare") owns all rights to this unpublished work and intends to maintain this work as confidential. Criticare may also seek to maintain this work as an unpublished copyright. This publication is to be used solely for the purposes of reference, operation, maintenance or repair of Criticare equipment. No part of this publication may be reproduced in any manner or disseminated for other purposes.

In the event of an inadvertent or deliberate publication, Criticare intends to enforce its rights to this work under copyright laws as a published work. Those having access to this work may not copy, use or disclose the information in this work unless expressly authorized by Criticare to do so.

All product specifications, as well as information contained in this publication, are subject to change without notice.

All information contained in this publication is believed to be correct. Criticare Systems, Inc. shall not be liable for errors contained herein nor for incidental or consequential damages in connection with the furnishing, performance, or use of this material.

This publication may refer to information and products protected by copyrights or patents and does not convey any license under the patent rights of Criticare Systems, Inc., nor the rights of others. Criticare Systems, Inc. does not assume any liability arising out of any infringements of patents or other rights of third parties.

PROPERTY OF CRITICARE SYSTEMS, INC.

ALL RIGHTS RESERVED

504 OPERATOR'S MANUAL

TABLE OF CONTENTS

Introduction	1
504 Features	2
Theory of Operation	3
Precautions	4
Quick Guide to Basic Operation	6
Basic Guide to UltraSync™ Operation	9
Sensor Placement	10
Waveform Monitoring	11
Front Panel	14
Back Panel	17
Configuring the Monitor	18
Setting the Time and Date	20
Setting the Pulse Tone and Alarm Values	20
Smart Alarms	21
Neonatal Monitoring	22
Averaging Times	22
Memory	22
Using UltraSync	23
Trending	24
Integral Printer	31
Interfacing the 504 with External Devices	33
Printers	33
Computers	38
Strip-chart Recorders	40
Maintenance	43
Status Messages	44
504/504-US Accessories	46
Specifications	47
Warranty	48
Service Return Policy	49

Information that applies only to the 504-US and 504-USP is presented in gray.

Multi-Site Sensor Instructions
Interfacing Instructions

Appendix
Appendix

INTRODUCTION

Criticare's 504 series of pulse oximeters incorporates both easy-to-read LED displays of pulse rate and oxygen saturation and a highly-visible LCD for signal quality confirmation, trend information and alarm set-up.

The 504 series includes the following models:

- 504 (pulse oximeter)
- 504P (pulse oximeter with integral printer)
- 504-US (pulse oximeter with ECG UltraSync™)
- 504-USP (pulse oximeter with ECG UltraSync™ and integral printer).

This manual covers all of the models in the series. Not all features apply to all models.

There is a separate section on the integral printer which applies to both the 504P and the 504-USP.

Information that applies to US models only is identified in gray.

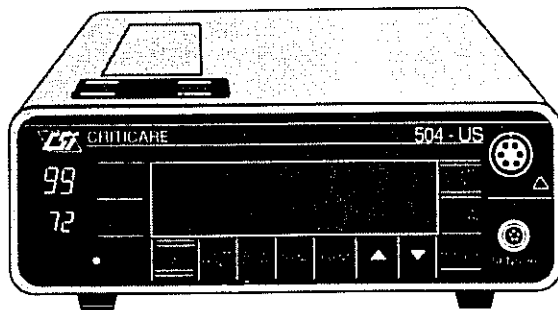

504-USP

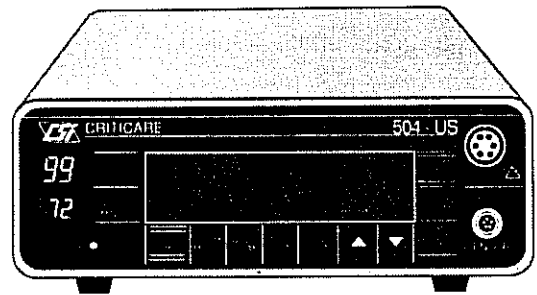

504-US

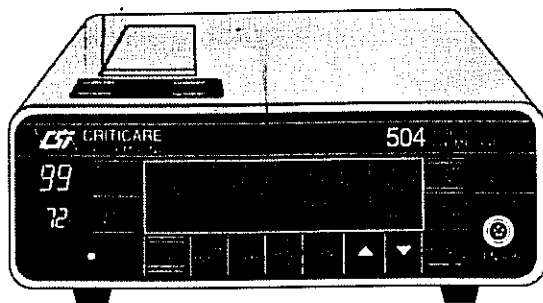

504P

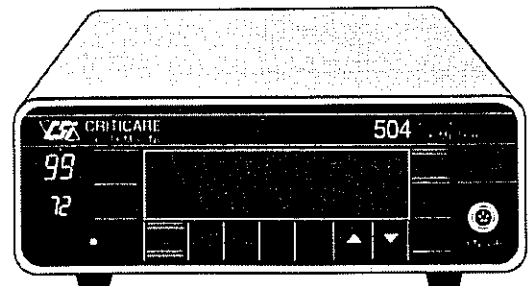

504

504 FEATURES

ULTRASYNCTM

The UltraSync™ feature correlates the ECG signal to the plethysmographic waveform obtained from the oxygen saturation sensor. This enhances the performance of the oximeter in low perfusion states and reduces the effect of motion artifact. It is recommended that UltraSync™ be used in low perfusion states including hypothermia and shock, and when motion may affect readings (during stress testing and transport).

NEONATAL MONITORING

All 504 monitors have user-selectable neonatal software. This software uses neonate-specific algorithms to accurately track a neonate's saturation and pulse rate.

SMART ALARMS

Smart Alarms are also incorporated in every 504 model. When enabled, these alarms establish high and low alarm limits for both pulse rate and oxygen saturation. These limits are derived from the patient's baseline or current readings.

For example, if a patient has a baseline oxygen saturation reading of 99%, and a pulse rate of 70 BPM, then the smart alarm limits would automatically be set at OFF, 94%, 85 BPM and 55 BPM.

TRENDING

All 504 models incorporate a wide selection of trending options. There are several resolution and time modes. An EVENT key on the front panel places a marker on the trend screen, signaling events such as intubations, extubations, oxygen and drug administration.

EXTERNAL INTERFACING

All 504 models have extensive interfacing capabilities, including analog and digital modes. It is possible to interface the pulse oximeter with strip-chart recorders, external text (ASCII) printers, external graphics (Epson-compatible) printers, and computers.

THEORY OF OPERATION

The 504 is a portable, AC or battery operated device which measures percent arterial oxygen saturation and pulse rate based on the principles of spectrophotometry and plethysmography.

The sensor consists of LED's and a photodetector. The LED's emit two specific wavelengths of light which are absorbed selectively by oxyhemoglobin and reduced hemoglobin. The photodetector measures the intensity of each wavelength that is transmitted through the monitoring site.

The two wavelengths of light used in the 504 models provide a determination of oxyhemoglobin and reduced hemoglobin levels. The resultant measurement is the ratio of oxyhemoglobin to the total hemoglobin available for binding to oxygen (often referred to as functional or partial saturation).

$$\% O_2 \text{ saturation} = \frac{\text{Oxyhemoglobin}}{\text{Oxyhemoglobin} + \text{Deoxyhemoglobin}} \times 100\%$$

Dyshemoglobins, such as carboxyhemoglobin and methemoglobin, are not directly measured and therefore are not factored into the measurement.

APPLICATIONS

Continuous arterial oxygen saturation monitoring is valuable in any situation where oxygen administration is indicated. Real time information allows for earlier detection of hypoxia or hyperoxia than arterial sampling. The effects of changes in oxygen therapy can be assessed immediately, and in certain situations, the frequency of blood gas analysis may be reduced.

ULTRASYNC™

ECG synchronization in the US models correlates the plethysmograph to the ECG waveform. This correlation allows for signal processing of the pulse waveform, reducing noise before a saturation measurement is made. Noise during motion artifact, is averaged out and does not interfere with the saturation measurement. In low perfusion states, noise due to limiting factors in the electronics is greatly reduced.

Even when a pulse waveform may not be discerned, the US feature allows for accurate saturation measurements.

PRECAUTIONS

NOTE

Federal law restricts this device to sale by or on the order of a physician.

NOTE

Read this manual before attempting clinical use of the Criticare Systems, Inc. 504, 504P, 504-US or 504-USP pulse oximeters.

CAUTION

Possible explosion hazard. Do not use in the presence of flammable anesthetics.

NOTE

For optimum performance, the operating environment should meet the following requirements:

Temperature: 15-40° C (59-104° F)
Humidity: 15-90% (non-condensing)

NOTE

Do not place the sensor on the same extremity where a blood pressure cuff or arterial line has been placed. The occlusion of the blood flow during blood pressure determinations may affect saturation readings.

NOTE

Inspect the pulse oximeter application site every four to six hours to make certain supplemental tape has not been applied too tightly. If there is any redness or skin irritation, remove the sensor and apply at a different location. If extra tape is required to secure the finger sensor, wrap the tape around the cable, not the sensor itself. Do not strain the sensor cable.

CAUTION

ECG electrodes should be placed as far as possible from the point of application of the defibrillator paddles.

NOTE

No adverse effects are known when the 504 is used in the presence of pacemakers or other electrical stimulators.

CAUTION

Total patient leakage current will be equal to the sum of the leakage currents of each device connected to the patient.

NOTE

Use the Pulse Oximeter only with a CSI approved AC charger. Use of a non-approved device may cause hazard to operator or patient.

NOTE

Connect the AC Charger to hospital grade outlets only.

NOTE

In order to assure adequate battery power at all times, charge the unit following extended battery use.

NOTE

The display screen is protected with an anti-glare covering. Use only non-abrasive cleaners that do not mar the surface.

NOTE

Examine the ECG electrode sites daily for skin irritation. Change the electrodes and reposition if there is any sign of inflammation.

CAUTION

Use only the patient cable or input cable provided by CSI for the ECG signal input.

CAUTION

The conductive parts of the lead electrodes and associated connectors for Type CF electrocardiographs, including the neutral electrode, should not come in contact with other conductive parts including earth.

WARNING

The Model 504-US (UltraSync) is not to be used for intracardiac ECG application.

NOTE

The 504 is electrically protected from damage due to sensor application on a patient undergoing a procedure involving electrosurgery. This will also protect the patient from harmful current densities at the sensor and electrode sites in the event of a defect in the electrosurgical unit's neutral electrode. To minimize the effects of electrosurgical interference, the sensor and electrodes should be placed as far as possible from the surgical site and neutral electrode. The ECG waveform and plethysmograph may be distorted under some combinations of electrode placement and electrosurgical power levels.

QUICK GUIDE TO BASIC OPERATION

The following steps describe how to use the 504 to obtain oxygen saturation and pulse rate measurements, using the finger sensor and wrist electrodes (where applicable). *This section is not intended as a replacement for reading the manual in its entirety.*

- Attach the finger sensor to the oximeter.
- Turn the 504 pulse oximeter on by pressing the POWER key on the front panel. The monitor emits a very short beep, followed by a test of the LED's and the LCD screen.
- Place the finger sensor on a finger, as illustrated:

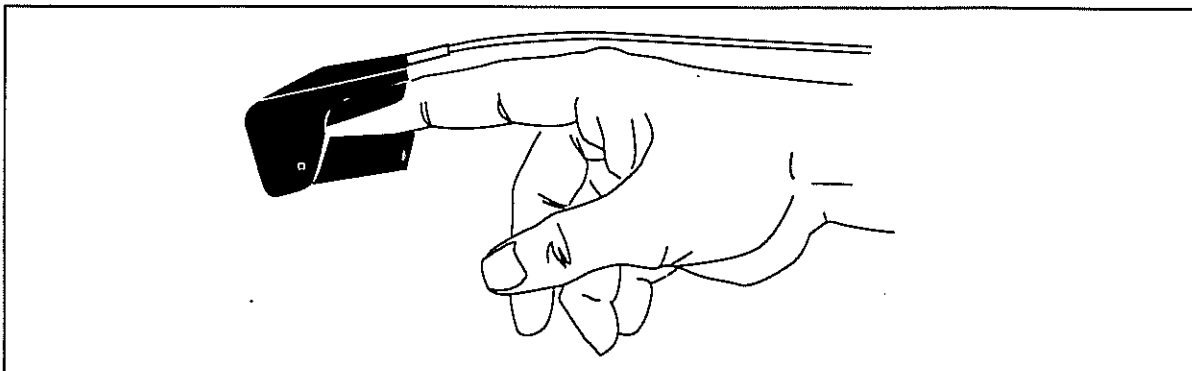

Do not put tape over the sensor housing. If the sensor needs to be secured, place tape around the cable immediately behind the sensor.

- Watch the display for a pulse waveform. After several pulses are detected (as indicated by the pulse tone), the pulse rate and oxygen saturation readings will display on the LED's.

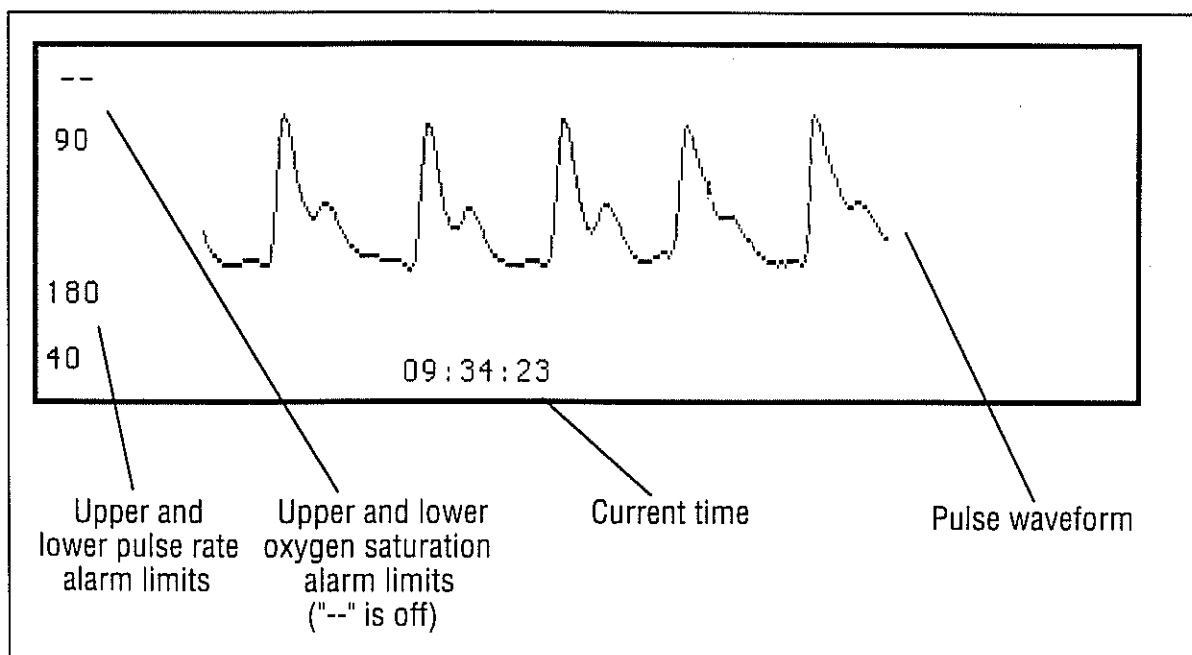

- If the readings do not display, check the display for the following messages:

SENSOR	(sensor is off patient or too much light is present)
SENSOR SGNL	(check the connection of the sensor to the 504 monitor)
HIGH AMBIENT	(shield the sensor from ambient light)
SEARCH	(no detectable pulse - searching)

These messages indicate the sensor may need to be repositioned. See the Status Message Section for more information.

- To turn the pulse tone off, press PULSE VOLUME.
- To reduce the pulse tone volume (or turn it off), press and hold the PULSE VOLUME key. "PULSE VOL: 3" displays along the bottom right side of the screen while a constant tone sounds. Continue to hold the key until "PULSE VOL: 0" is displayed. This silences the pulse tone. To hear the range of volumes, press and hold PULSE VOLUME. The volumes will be emitted and displayed as the key is held.
- To temporarily silence any alarm for two minutes, press the ALARM SILENCE key. The LED corresponding to the alarm continues to flash, and the alarm message displays on the LCD. Adjust the alarm volume in the same manner as the pulse volume using the ALARM SILENCE key.
- To enable the smart alarms, press the ▼ key below the LEARN legend. If LEARN is not displayed, the smart alarm function has not been turned on in the Alarm Menu screen. To enable the smart alarms feature, see the *Configuring The Monitor* section for more information.

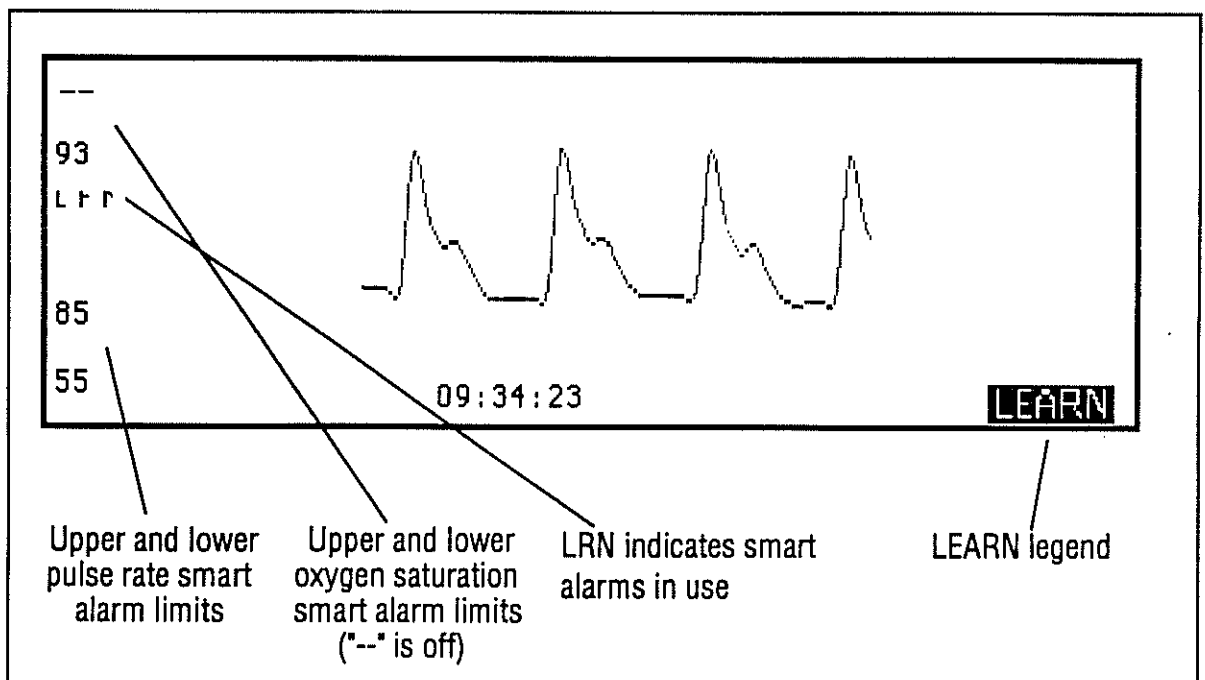

The alarm limits display on the left side of the LCD. The alarm limits, from top to bottom, are:

High saturation limit
Low saturation limit
High pulse rate limit
Low pulse rate limit

“LRN” (for LEARN) displays between the saturation and pulse rate limits.

“SYNC” may also display, indicating the UltraSync™ mode is in operation.

To turn off the smart alarms, press the ▼ key below LEARN. The alarm limits are now the pre-set, or default values. For more information on manually setting alarms, see the *Configuring The Monitor* section.

- The 504P and 504-USP can print any waveform screen on the printer. Printouts include the date and time, O₂ saturation and pulse rate. Press the PRINT key on the printer module.

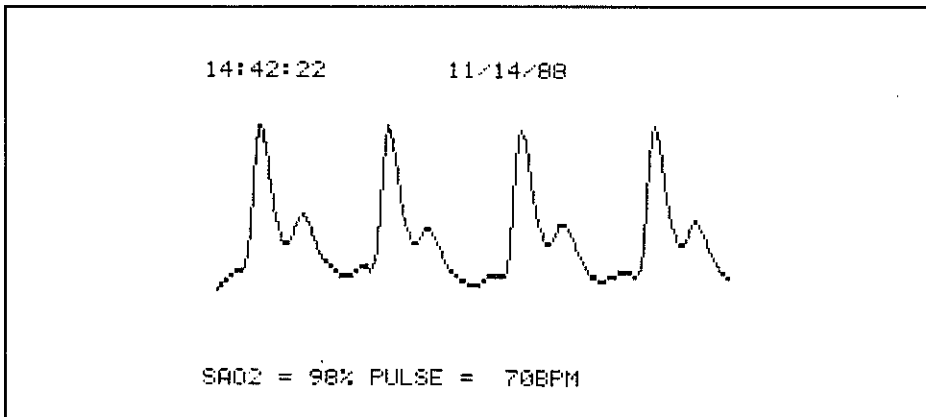

BASIC GUIDE TO ULTRASync™ OPERATION

- It is possible to use UltraSync™ by using the wrists as electrode sites. Attach the red (LL) electrode to the left wrist and attach the white (RA) electrode to the right wrist to produce an ECG signal.

To view the ECG waveform, press the WAVEFORM key. The ECG waveform will expand automatically to the full height of the screen. The bar to the left side of the screen is equivalent to 1 millivolt in height. It reflects the strength of the ECG signal.

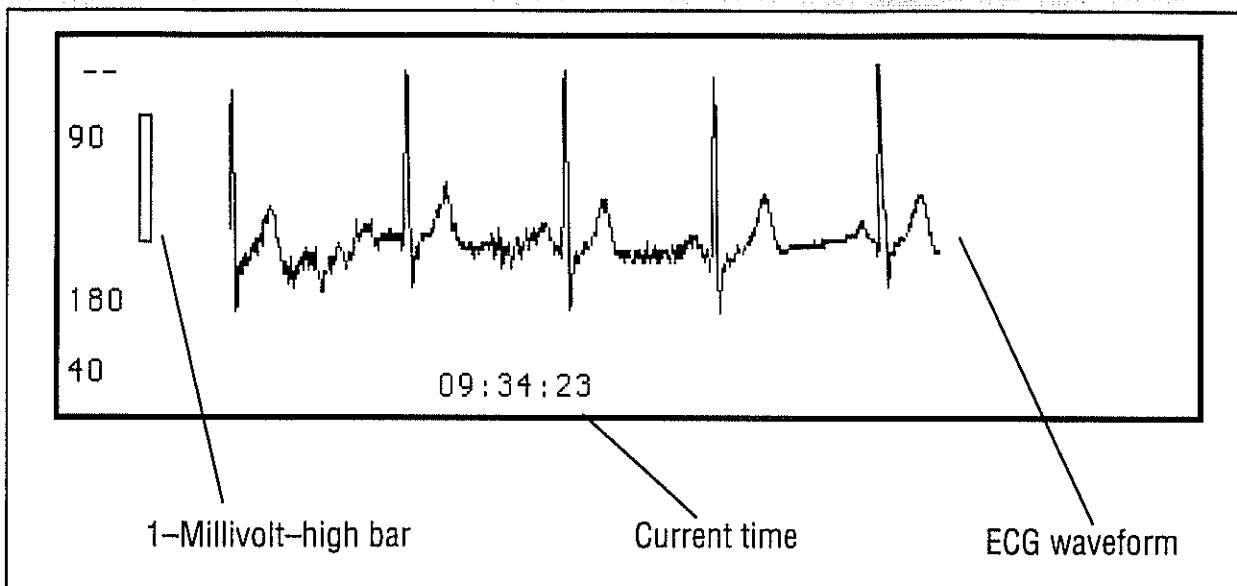

To view both the pulse and ECG waveforms, press WAVEFORM again. The pulse waveform displays on top, with the ECG below. The 1-millivolt bar also displays to the left of the ECG signal. When the UltraSync™ feature is functioning, "SYNC" displays on the left side of the LCD.

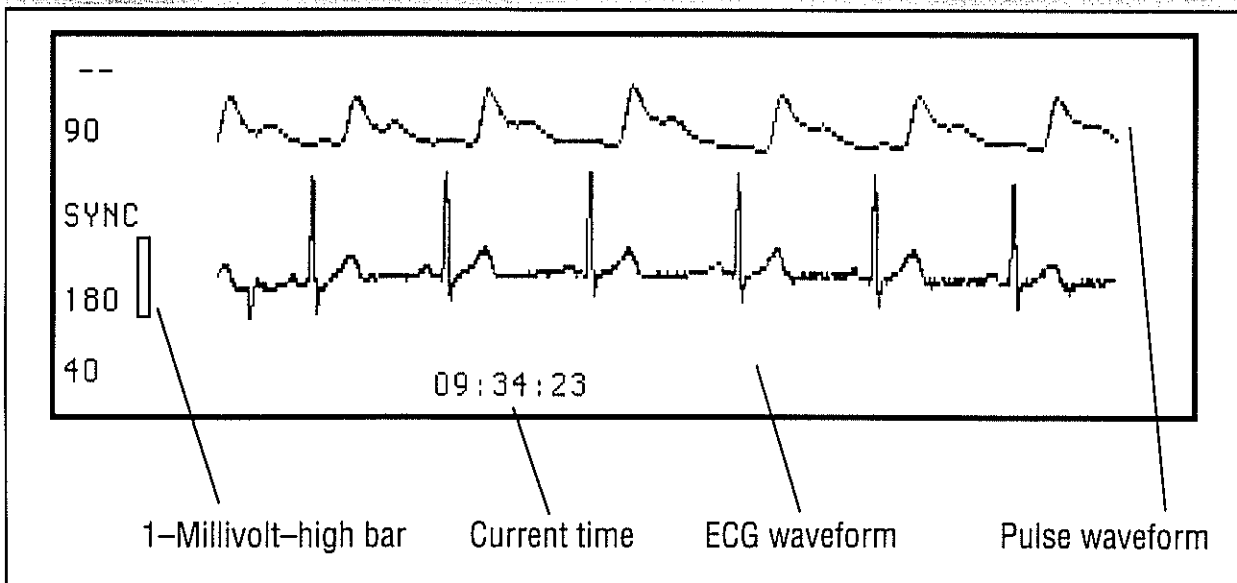

SENSOR PLACEMENT

FINGER SENSOR

Place the sensor on a finger as shown. Do not put tape over the sensor housing. If the sensor needs to be secured, place tape around the cable immediately behind the sensor.

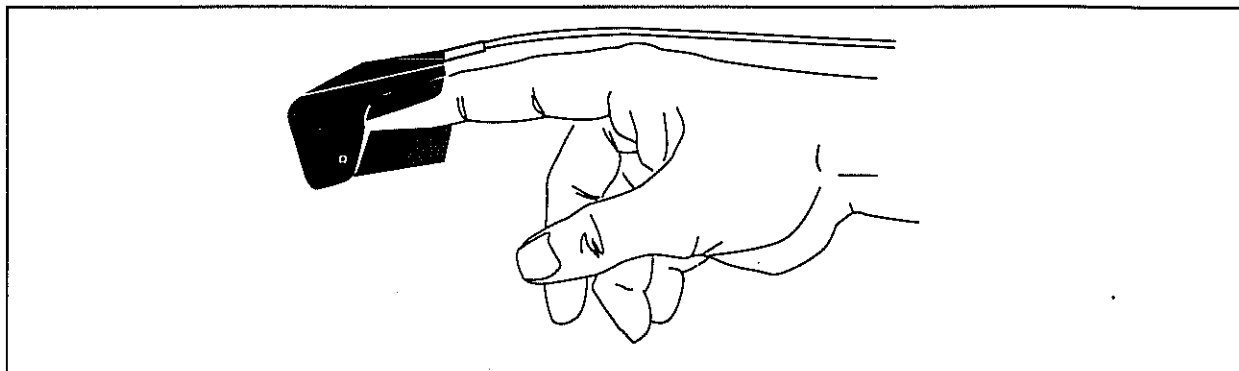

ECG LEADS

In the Lead II configuration, the right arm (RA-white) electrode is placed on the right side of the sternum below the clavicle and medial to the pectoral muscles. The left leg (LL-red) electrode is situated at the level of the lowest palpable rib on the left side of the chest in the anterior axillary line. The left arm (LA-black) electrode is placed at the upper left rib cage area, above the left leg (LL-red) electrode.

The monitor records the electrical activity between the RA and LL electrodes. Other electrode sites can be used, as long as a stable, clean ECG is obtained. The wrists may also be used; apply the right arm (RA-white) electrode to the right wrist, and apply the left leg (LL-red) electrode to the left wrist. This facilitates the use of UltraSync™ in outpatient situations.

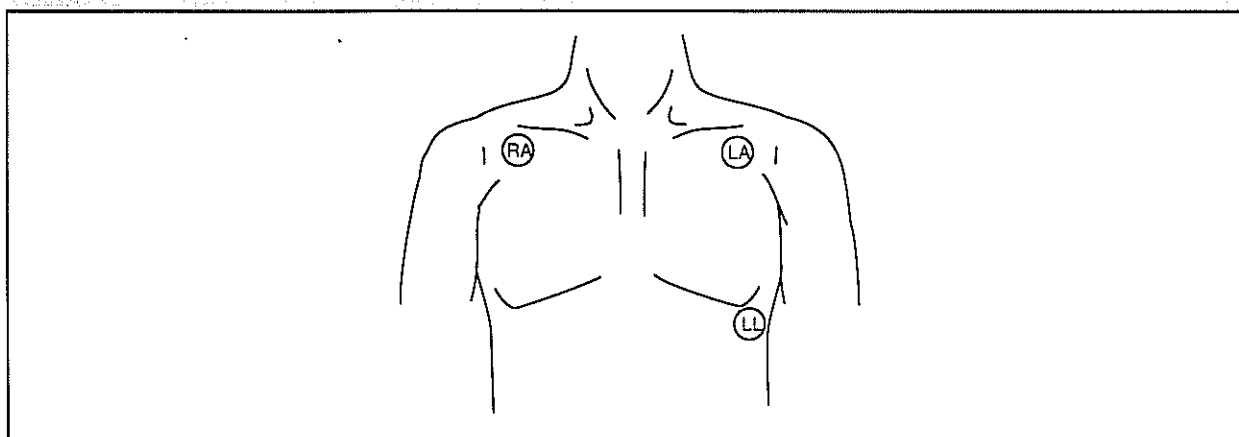

NOTE

Use only the CSI ECG cable and leads.

WAVEFORM MONITORING

The pulse waveform displays when the monitor is turned on. (This is the only waveform screen on the non-US models.) This screen verifies the quality of the signal obtained by the sensor. If the signal is very small, or if there is a great amount of motion artifact, a better signal may be obtained by moving the sensor to another site.

The WAVEFORM key cycles the display screens.

PULSE WAVEFORM SCREEN

To magnify the pulse waveform two, four or six times, press MAGNIFY. The magnification factor, "X2 MAG", displays in the upper right of the LCD. Press the MAGNIFY key again for 4X magnification, and again for 6x magnification. To return to the non-gained waveform, press MAGNIFY again.

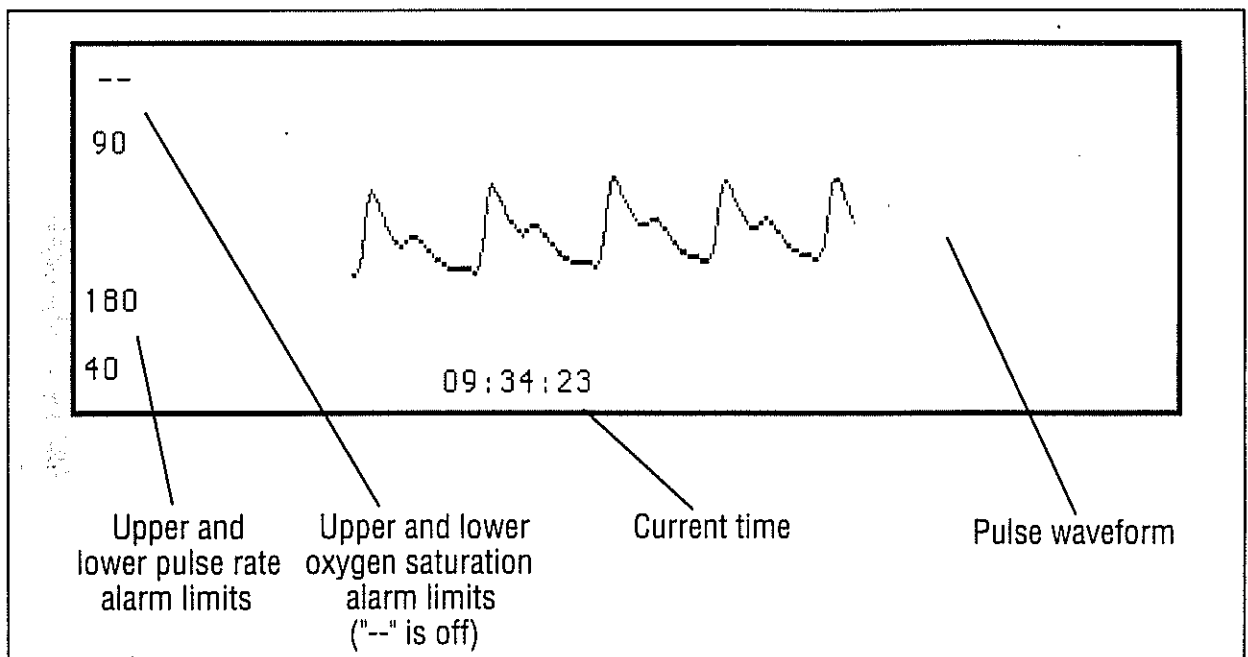

ECG WAVEFORM SCREEN

The 504-US and 504-USP models also have the capability to display the ECG waveform. To display the ECG, press WAVEFORM while in the pulse waveform screen. An auto-gained ECG waveform displays; the signal automatically is displayed at full height. An indication of signal strength, a 1-millivolt bar is displayed on the left side of the LCD.

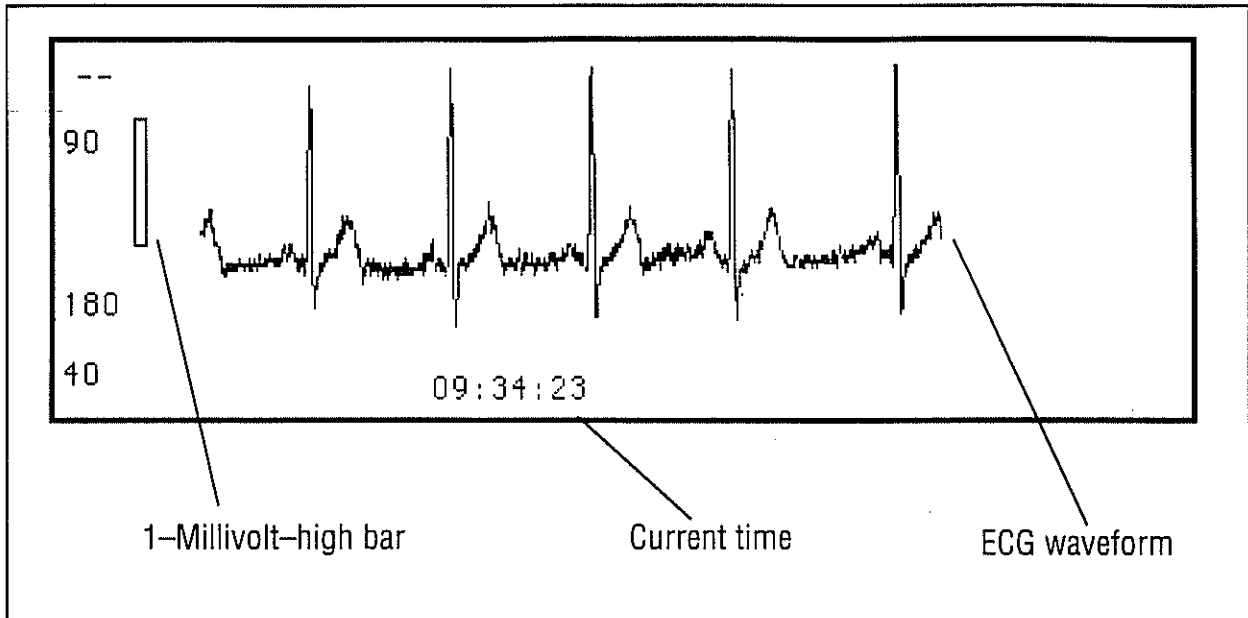

ECG MESSAGES

- | | |
|----------|--|
| ECG LOST | QRS complexes are not being detected. Check patient. Warning tone will sound |
| LEAD OFF | An ECG lead is loose or disconnected. Check leads. Warning tone will sound |
| SYNC | The monitor is in the UltraSync™ mode |
| ECG | QRS complexes are being detected - displayed before SYNC |

For more information on ECG lead placement and the US function, see *Configuring The Monitor*.

PULSE / ECG WAVEFORM SCREEN

Press **WAVEFORM**. The pulse waveform displays above the ECG waveform. The pulse waveform may be displayed at two, four and six times its normal display size by pressing **MAGNIFY**. The ECG waveform remains at its autogained size, with the 1-millivolt bar displayed to the left side of the waveform.

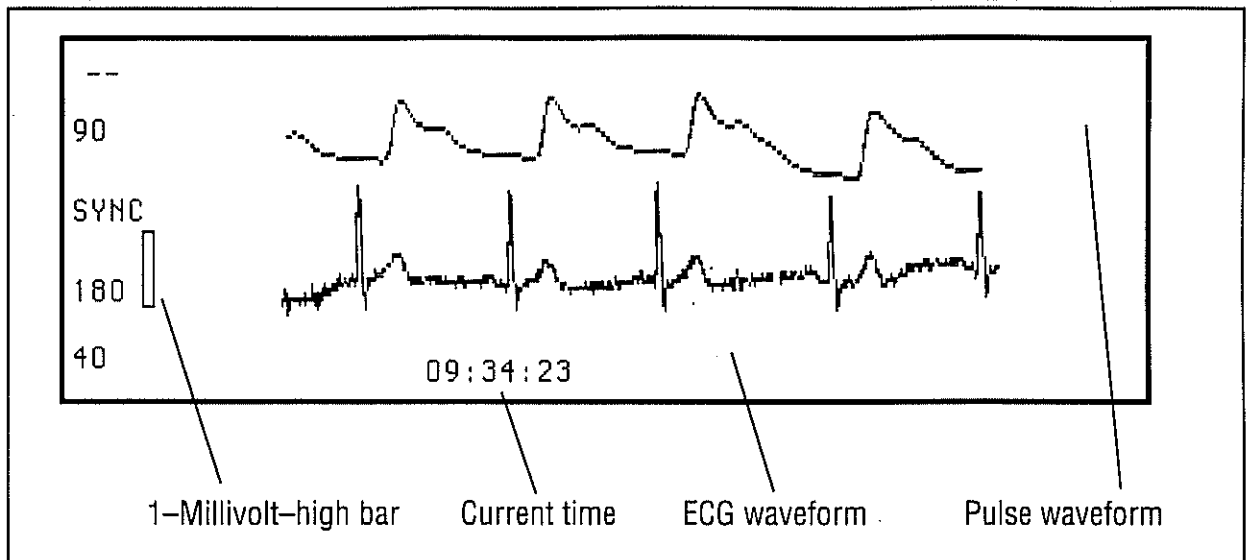

To return to the pulse waveform screen, press **WAVEFORM** again.

SUMMARY

The **WAVEFORM** key changes the waveform displayed. The cycle is pulse waveform, ECG waveform (where applicable), pulse and ECG waveforms, pulse waveform. The **MAGNIFY** key changes the magnification of the pulse waveform; the cycle is 2X, 4X, 6X, and non-gained.

FRONT PANEL

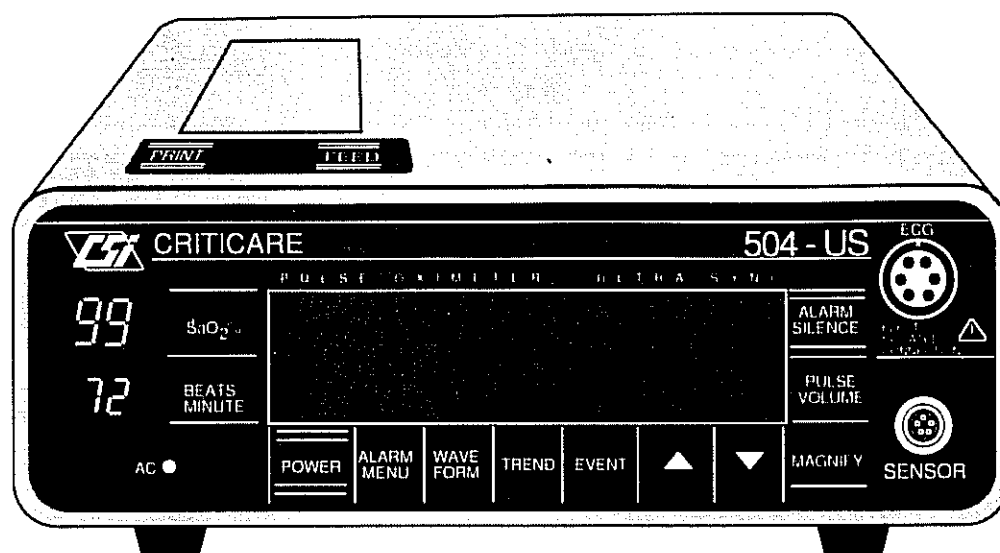

AC

When lit, the AC LED indicates the AC Charger is connected to the 504 and is charging the internal battery.

POWER

POWER turns the 504 ON or OFF.

ALARM MENU

When pressed once, ALARM MENU displays the Alarm Menu screen. Alarm parameters are selected by pressing ALARM MENU momentarily.

The Configuration Screen is displayed by pressing and *HOLDING* ALARM MENU for 2 seconds. Configuration parameters are selected by pressing ALARM MENU momentarily.

WAVEFORM

Displays a waveform.

First press: Pulse waveform (only waveform for 504, 504P).

Second press: ECG waveform displays.

Third press: Pulse and ECG waveforms display.

Fourth press: Returns to pulse waveform.

TREND

Displays collected trend data.

- First press: Oxygen saturation trend
- Second press: Pulse rate trend
- Third press: Oxygen saturation and Pulse rate trend
- Fourth press: Returns to Oxygen saturation trend

Note: MAGNIFY magnifies or reduces the trend size displayed while a trend is displayed.

Note: Trend information is not collected or displayed if the date or time is not set.

EVENT

EVENT places an event marker on the trend screens.

When the SERIAL FORMAT parameter is set to ASCII PRINTER, GRAPH1 PRINTER or GRAPH2 PRINTER, EVENT acts as a "Print on demand" key.

When the SERIAL FORMAT parameter is set to DIF TREND, BINARY TREND, or ASCII TREND, and the Configuration Screen is displayed, EVENT outputs the trend data through the serial port. To cancel, press EVENT.



When the Alarm Menu or Configuration Screen is displayed, ▲ increases the alarm settings, clock and calendar values.

When a trend is displayed, ▲ scrolls forward in time in the trend screen.



When the Alarm Menu or Configuration Screen is displayed, ▼ decreases the alarm, clock and calendar settings.

When a trend is displayed, ▼ scrolls backward in time through trend screen.

When LEARN is displayed above the ▼ key, ▼ activates and exits the smart alarm mode. LRN displays at left side of screen when smart alarms have been activated.

MAGNIFY

When the pulse waveform displays, MAGNIFY increases the size of the waveform.

- First press: 2 times ("X2 MAG")
- Second press: 4 times ("X4 MAG")
- Third press: 6 times ("X6 MAG")
- Fourth press: Returns to non-gained pulse waveform

When a trend screen displays, MAGNIFY switches between the magnified and non-magnified view of the trend data.

- 4 minute magnified screen is changed to 1.75 hour non-magnified screen and back
- 8 minute magnified screen is changed to 3.5 hour non-magnified screen and back
- 20 minute magnified screen is changed to 8.75 hour non-magnified screen and back

PULSE VOLUME

Silences the pulse tone, adjusts the pulse tone volume.

ALARM SILENCE

Pressing ALARM SILENCE disables the audible alarm for two minutes. "ALARM SILENCE" appears on the display. Alarms may be re-enabled on demand by pressing ALARM SILENCE again.

Depressing and holding changes the alarm volume. "ALARM OFF" appears on the display when the volume is set to 0.

ECG

The 6-pin jack for the CSI AAMI ECG connector.

SENSOR

The jack for CSI oxygen saturation sensors.

PRINTER MODULE**PRINT**

If the PRINT INTERVAL parameter on the Alarm Menu screen are set to 0 min and 0 seconds, pressing PRINT will print the current screen on the integral printer.

If the PRINT INTERVAL parameter on the Alarm Menu screen are set to any other interval, PRINT initiates interval printing.

FEED

Advances the printer paper.

504US/504USP

SYMBOL	DESCRIPTION
~	Alternating Current
	<p>Type CF Equipment: 'Type C' equipment with an 'F-type' isolated (floating) part.</p> <p>'Type C' equipment has an internal electrical power source which provides a higher degree of protection against electric shock particularly regarding allowable leakage currents than that for Type BF equipment and the reliability of the protective earth connection.</p> <p>'F-type' isolated (floating) applied parts are isolated from all other parts of the equipment to such a degree that the allowable leakage current under single fault conditions is not exceeded when 1:1 times the highest rated means voltage is applied between the applied part and earth.</p>

BACK PANEL

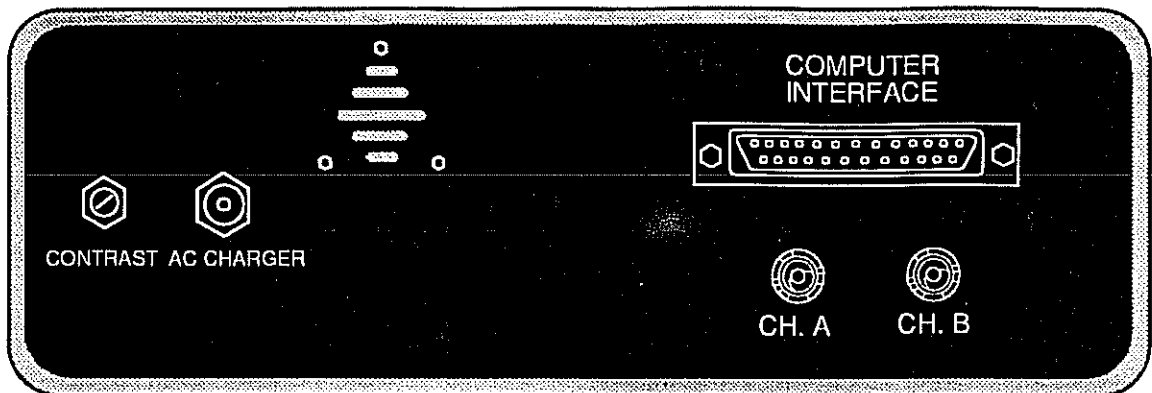

CONTRAST

Changes the display contrast on the LCD.

AC CHARGER

Use only the CSI 902 or 905 AC Chargers. The Model 902 Charger has an integral North American style plug and plugs directly into the wall socket for 120 VAC, 60 Hz service. The Model 905 Charger uses a detachable line cord which comes from the factory unterminated. This cord is stripped for installation of the correct plug. Connect the mains plug into the wall socket and the IEC connector into the charger for 220/240 VAC, 50 Hz service. Connect the charger's small round plug into the monitor's jack labelled AC Charger.

COMPUTER INTERFACE

RS-232C DB-25 serial port for interfacing the 504 to computers and external printers.

CH. A, CH. B

"Channel A" and "Channel B" – BNC connectors for analog output to strip-chart recorders, digitizers and oscilloscopes. Output type (pulse wave, ECG, test mode, pulse rate, oxygen saturation) is set in the Configuration Screen.

504/504P

SYMBOL	DESCRIPTION
~	Alternating Current
	<p>Type BF Equipment: 'Type B' equipment with an 'F-type' isolated (floating) part.</p> <p>'Type B' equipment has an internal electrical power source which provides an adequate degree of protection against electric shock such as allowable leakage currents and the reliability of the protective earth connection.</p> <p>'F-type' isolated (floating) applied parts are isolated from all other parts of the equipment to such a degree that the allowable leakage current under single fault conditions is not exceeded when 1:1 times the highest rated means voltage is applied between the applied part and earth.</p>

CONFIGURING THE MONITOR

USING THE ALARM MENU AND CONFIGURATION SCREENS

The Alarm Menu and Configuration Screen work in the same manner. To access the Alarm Menu, press ALARM MENU. The left side of the screen has abbreviated instructions on using the alarm screen. Alarm limits and other parameters are displayed on the right. The value or parameter that can be changed is highlighted using reverse text.

Alarms parameters are changed are in the Alarm Menu screen. They include:

ALARM PARAMETER	RANGE
• High oxygen saturation	70-99, OFF
• Low oxygen saturation	1-99, OFF
• High pulse rate	80-250, OFF
• Low pulse rate	20-160, OFF

In addition, the parameters SHOW ALARMS and SMART ALARMS are on the Alarm Menu screen.

The screenshot shows the ALARM MENU screen. On the left, there are instructions: "ALARM MENU", "SELECT PARAMETERS WITH ALARM MENU KEY", "CHANGE LIMIT VALUES WITH ▲/▼ KEYS", and "HOLD ALARM MENU KEY FOR CONFIG SCREEN". On the right, the parameters are listed: "O2 SAT: HIGH ALARM: 99", "LOW ALARM: 90", "PULSE: HIGH ALARM: 180", "LOW ALARM: 40", "SHOW ALARMS: YES", "SMART ALARMS: ON", "INTVL PRINT: MIN: 0", and "SEC: 0". The "HIGH ALARM: 99" and "LOW ALARM: 90" for O2 SAT are highlighted with reverse text. The "HIGH ALARM: 180" and "LOW ALARM: 40" for PULSE are also highlighted with reverse text. Annotations with lines point to these elements: "Instructions" points to the left text, "Highlighted parameter; change by pressing ALARM MENU" points to the O2 SAT parameters, and "Highlighted value; change by pressing ▼/▲" points to the PULSE parameters.

The first value is HIGH ALARM for O₂ saturation. Press ALARM MENU again to highlight LOW ALARM for O₂ saturation. The ALARM MENU cycles through the parameters. To exit the Alarm Menu screen at any time, press either WAVEFORM or TREND.

To change a value, press the ▲ and ▼ keys.

NOTE

Alarm limits remain in memory when the power is turned off. The exception is low oxygen saturation, which resets to 85% if the value was set to < 85% when the unit was turned off.

SHOW ALARMS determines whether or not the alarm limits are shown on the waveform screens. If YES, the alarm limits are shown on the left side of the waveform screen. If NO, a 16 segment, non-gated pulse ladder displays.

SMART ALARMS determines if the smart alarms will be enabled on the waveform screens. If ON, the smart alarms are available by pressing the ▼ key below the LEARN legend. If OFF, the smart alarms are not enabled.

INTERVAL PRINT (Printer models only) determines the time between printings of the saturation and pulse rate on the integral printer. The setting of 0 minutes, 0 seconds enables demand printing only. Any other value will cause the printer to print out the time, pulse rate and saturation values at the specified interval. The print interval may be set at any interval between 5 seconds and 99 minutes. Note: Press the PRINT key to begin interval printing.

To access the Configuration Screen, press and **hold** ALARM MENU for two seconds. To select a parameter, press ALARM MENU. To change the highlighted parameter value, use the ▲ and ▼ keys.

CONFIGURATION SCREEN	
PATIENT: ADULT	AVERAGE: 12 SEC
TREND RESOLUTION:	1.75 HOURS @ 1 SEC
BAUD RATE: 9600	SERIAL INTERVAL: 2 SEC
SERIAL FORMAT:	OFF
ANALOG CHANNEL A:	ECG WAVE
ANALOG CHANNEL B:	PULSE WAVE
TIME 14:44	DATE: 9/30/88

Highlighted parameter and value

EXAMPLE: SETTING THE TIME AND DATE

Set the time and date in the Configuration Screen. Access the Configuration Screen by holding the ALARM MENU key for 2 seconds. Press ALARM MENU until TIME is highlighted. The hour value is highlighted. Set the hour by using the ▲/▼ keys. Press ALARM MENU. Minutes are highlighted. Set the minutes. Press ALARM MENU to highlight the month. Set the month, day and year using the ALARM MENU, ▲ and ▼ keys.

The time and date must be set for the trend memory to function. User-set alarm limits will also be kept in memory only if the time and date are set.

SETTING THE PULSE TONE AND ALARM VOLUMES

At power up, both the alarm and pulse tone are audible. There are 10 volume levels. Operator-set values for alarm and pulse tone volume revert to default values when the unit is turned off.

PULSE TONE – DISABLING AND ADJUSTING VOLUME

To disable the pulse tone, press and release the PULSE VOLUME key.

To change the volume of the pulse tone, press and hold the PULSE VOLUME key. The volume setting shows (on the waveform screens and the corresponding tone is heard. Continue to hold PULSE VOLUME until the desired volume is reached.

ALARM VOLUME – DISABLING AND ADJUSTING VOLUME

To temporarily disable an audible alarm for two minutes, press ALARM SILENCE. All error messages will continue to display. To re-enable the audible alarms before the two-minute period is finished, press ALARM SILENCE.

To change the volume of the alarm, press and hold the ALARM SILENCE key. The volume setting is shown on the waveform screen and the corresponding tone is heard. Continue to hold ALARM SILENCE down until the desired volume is reached.

SMART ALARMS

SMART ALARMS are alarm limits automatically set, based on a patient's current readings. To enable the SMART ALARM function, enter the ALARM MENU. Press and release until SMART ALARMS is highlighted. Use the ▲/▼ keys to turn the "Smart Alarms" on. When ON, the smart alarms are set by pressing the ▼ key below the LEARN legend. When OFF, the LEARN legend does not display and the smart alarm function cannot be used.

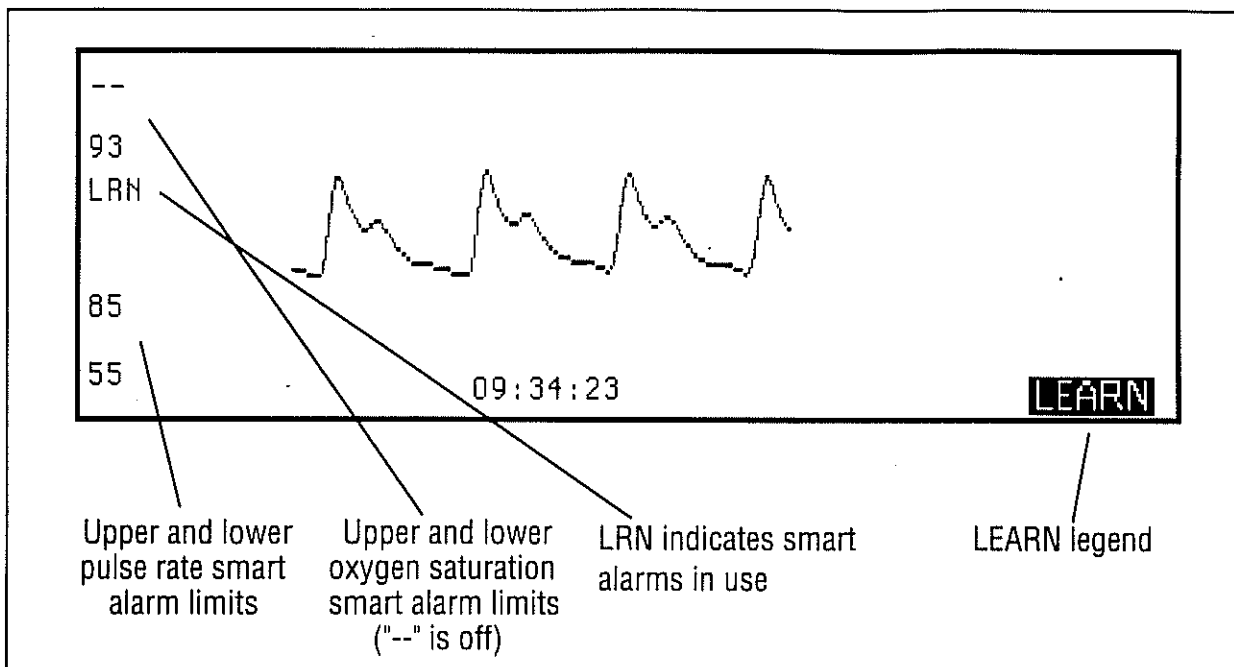

After pressing the ▼ key, the alarm limits display on the left side of the LCD. The alarm limits, from top to bottom, are:

- High saturation limit
- Low saturation limit
- High pulse rate limit
- Low pulse rate limit

"LRN" (for LEARN) displays on the left side of the screen. "SYNC" may display if the Ultra Sync mode is in use.

To return to the default or preset alarm limits, press the ▼ key below LEARN.

NEONATAL MONITORING

All 504 models have software specifically designed for monitoring neonates. To enable the neonatal mode, access the Configuration Screen by holding the ALARM MENU key for two seconds. The PATIENT parameter is highlighted. Select NEONATAL by pressing the ▲/▼ keys.

"NEONATAL MODE" displays on the waveform screen; indicating the neonatal software is in use. The neonatal monitoring mode is stored in memory. When the unit is powered on again, it will be in the neonatal mode, *if the time and date have been set.*

Note: the neonatal mode should not be used to monitor adults. This mode should only be used to monitor neonates with heart rates greater than 120 beats per minute.

AVERAGING TIMES

Select the averaging time in the Configuration Screen using the ▲/▼ keys. Twelve second averaging is the preferred averaging time for adult and neonatal monitoring. Select a shorter averaging time (< 12 seconds) for instances where there may be rapid, transient changes in saturation. Select a longer averaging time where there is a significant amount of motion. Selectable averaging times include 3, 6, 9, 12, 15, 18, and 21 seconds.

MEMORY

All alarm limits are stored in memory when the power is turned off *IF THE TIME AND DATE ARE SET.*

NOTE

The low saturation limit is always reset to 85 if the value was less than 85 when the power was turned off.

The pulse tone is reset to a default volume of 3 when the unit is powered on.
The alarm volume is reset to a default volume of 6 when the unit is powered on.

USING ULTRASYNC™

The UltraSync™ feature in US monitors greatly enhances the performance of the oximeter in cases of diminished perfusion and motion. To use the US feature, apply the ECG electrodes to the patient in the conventional Lead II electrode position:

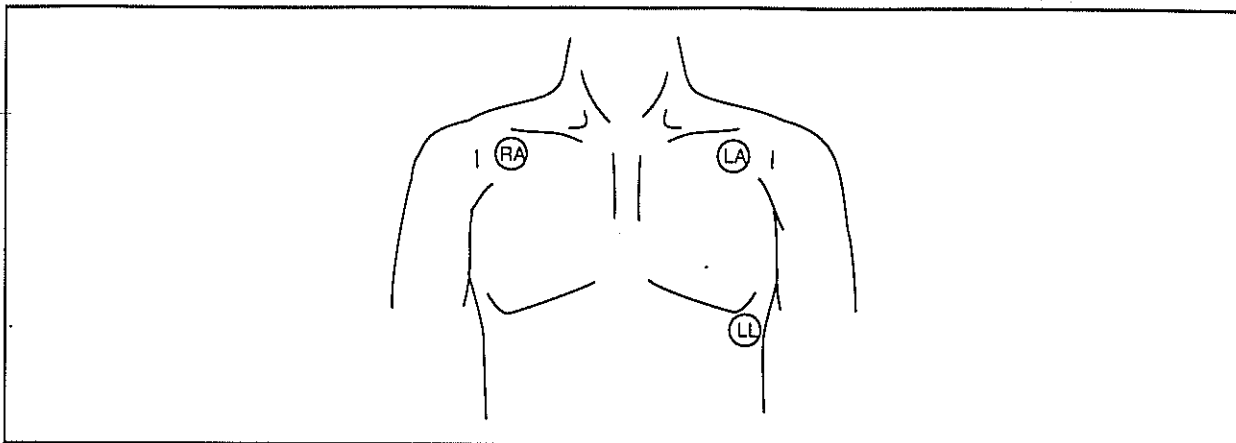

In this configuration, the right arm (RA-white) electrode is placed on the right side of the sternum below the clavicle and medial to the pectoral muscles. The left leg (LL-red) electrode is placed at the level of the lowest palpable rib on the left side of the chest in the anterior axillary line. The left arm (LA-black) electrode is placed at the upper left rib cage area, above the left leg (LL-red) electrode.

The 504-US records the electrical activity between the RA and LL electrodes. Other electrode sites can be used, provided a stable, clean ECG is obtained. The wrists may also be used. Apply the right arm (RA-white) electrode to the right wrist, and apply the left leg (LL-red) electrode to the left wrist. This facilitates the use of UltraSync in office and outpatient situations.

The 504-US can also be synchronized using the high level output of another ECG monitor. An optional ECG high-level input cable is available. The cable plugs directly into the ECG connector on the 504-US front panel.

NOTE

Any buffered, real-time (not time-delayed), 250mV to 2.5V ECG signal (such as defibrillator sync output) can be used for UltraSync™ operation. Contact your GSI sales representative for more information on this application.

When the ECG signal is detected by the 504-US monitor, "ECG" displays on the waveform screens. When the pulse rate detected by the sensor synchronizes with the ECG heart rate, the UltraSync mode is activated. "SYNC" displays on the waveform screens. Accurate oxygen saturation readings are now obtainable even during low peripheral perfusion states or periods of motion artifact.

If there are no detected QRS complexes, a warning tone will sound. "ECG LOST" displays on the waveform screens. If a lead comes off the patient, the warning tone also sounds, and "LEAD OFF" displays.

TRENDING

As oxygen saturation and pulse rate data is generated, the information is stored in the internal memory for graphic display on the trend screens. *Trend information is stored only if the date and time are set.*

Trended information provides the operator a visual means for analyzing retrospective data.

Access the configuration screen by holding ALARM MENU down for two seconds. Press and release ALARM MENU until TREND RESOLUTION is highlighted.

Select the desired TREND RESOLUTION using the ▼ and ▲ keys. There are six trend resolutions to choose from, ranging from 1.75 hours to 60 hours.

TREND RESOLUTIONS

User selectable trend resolutions are selected in the Configuration screen, and include:

- 1.75 hours @ 1 second resolution, averaged
4 minute magnified screen with 1 second/pixel
- 3.5 hours @ 2 second resolution, averaged
8 minute magnified screen with 2 seconds/pixel
- 8.75 hours @ 5 second resolution, averaged
20 minute magnified screen with 5 seconds/pixel
- 15 hours @ 15 second resolution, min/max captured
1 hour magnified screen with 15 seconds/pixel
- 30 hours @ 30 second resolution, min/max captured
2 hour magnified screen with 30 seconds/pixel
- 60 hours @ 1 minute resolution, min/max captured
4 hour magnified screen with 1 minute/pixel

In the 1.75, 3.5, and 8.75 hour trend resolution, values are averaged to obtain one number. Min/max captured means the maximum and minimum values in the time frame is trended. This will be represented as a line drawn from the minimum to the maximum for each time frame.

A pixel is a square on the LCD. Pixel is an abbreviation for "picture element".

Note: All previously trended information is erased whenever the trend resolution is changed.

TRENDING EXAMPLE

Select the 1.75 hour trend setting. Press TREND. The 4-minute oxygen saturation trend screen, "O2 SAT 4 MINUTE TREND," displays. Monitor for several minutes. After 30 seconds, trend data will be shown on the screen. All trend resolutions display a magnified view when TREND is initially selected. The dotted vertical line, displayed to the right of all the data, marks the current time. Time markers are displayed at the bottom of the screen.

O2 SAT 4 MINUTE TREND

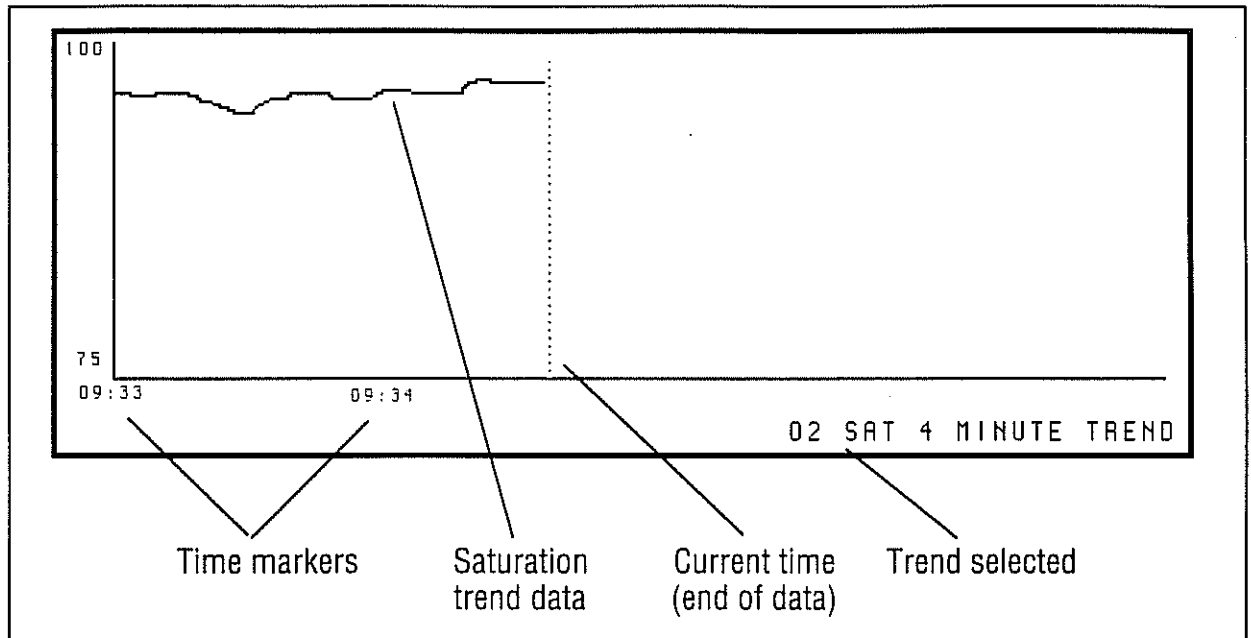

Subsequent depressions of TREND display the following:

BPM 4 MINUTE TREND (pulse rate in beats per minute)

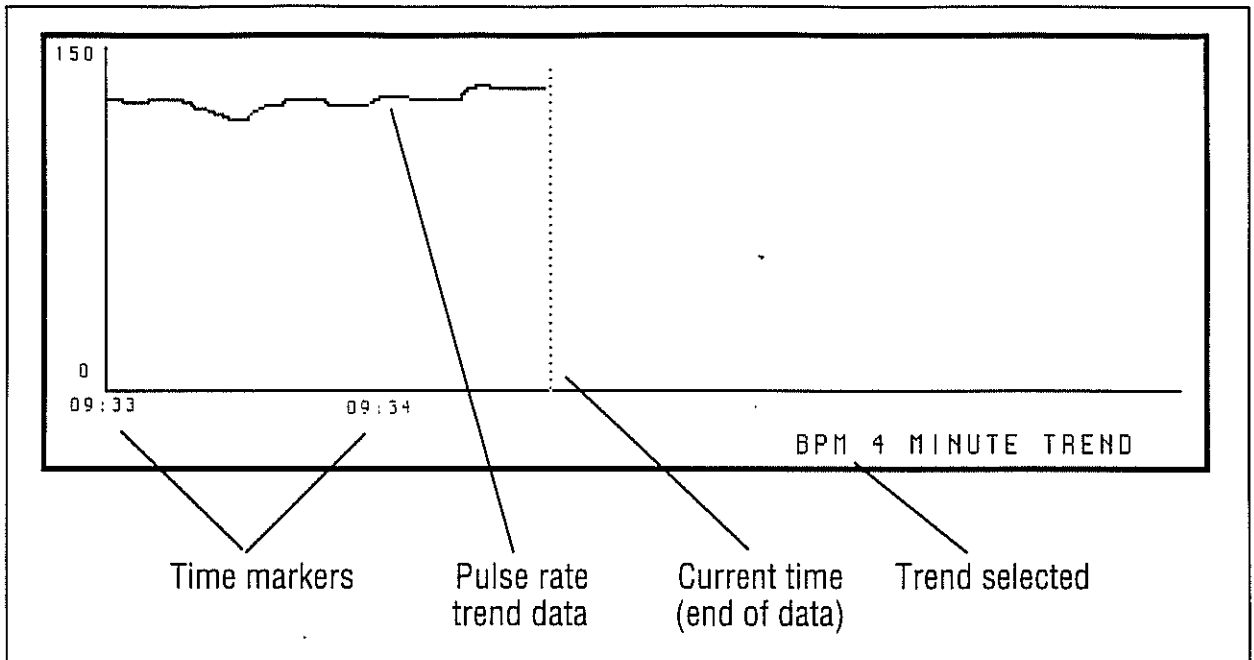

O2 SAT/BPM 4 MINUTE TREND

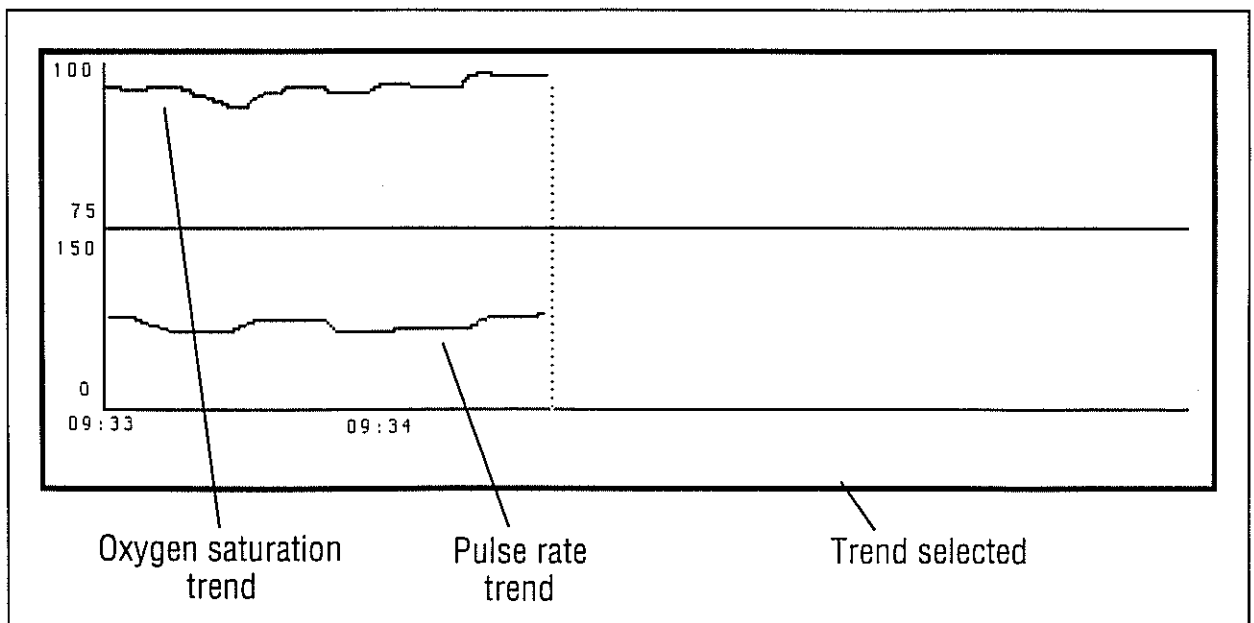

While in the trend screens, current O₂ Saturation and pulse rate values display on the LED's. Press TREND again to view the 4-minute oxygen saturation trend. To view the entire 1.75 hour trend display, press MAGNIFY. The trend data is displayed in the 1.75 hour format. A narrow, dotted vertical line indicates the present time.

Press the ▼ key. A cursor bar appears below the data. The ▲ key moves the cursor bar to the right (forward in time); the ▼ key moves the cursor bar to the left (backward in time). The date and times representing the beginning and end points of data above the cursor bar are shown on the bottom of the screen. To see this data in a magnified view, press MAGNIFY.

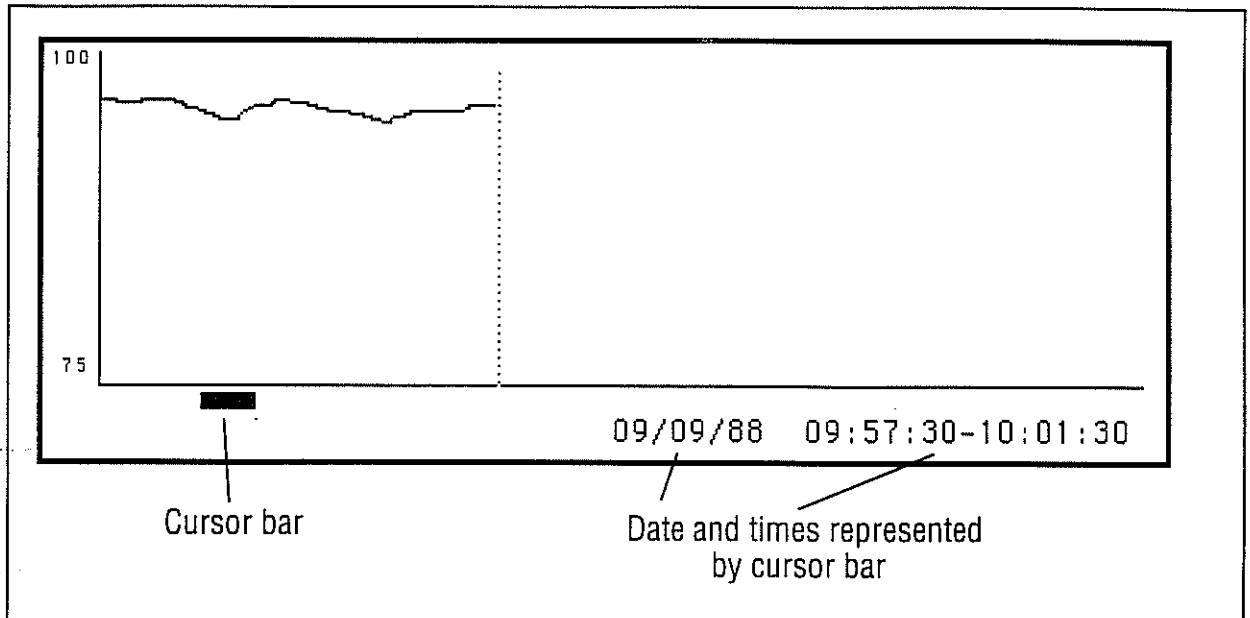

TREND	CURSOR BAR REPRESENTS:
1.75 hours	4 minutes
3.5 hours	8 minutes
8.75 hours	20 minutes
15 hours	1 hour
30 hours	2 hour
60 hours	4 hour

Press the ▼ or ▲ key. The narrow, unbroken vertical line is now the cursor. While the cursor is pressed to scroll through the magnified trend memory, the corresponding date, time, O₂ saturation and pulse rate values display at the bottom of the screen.

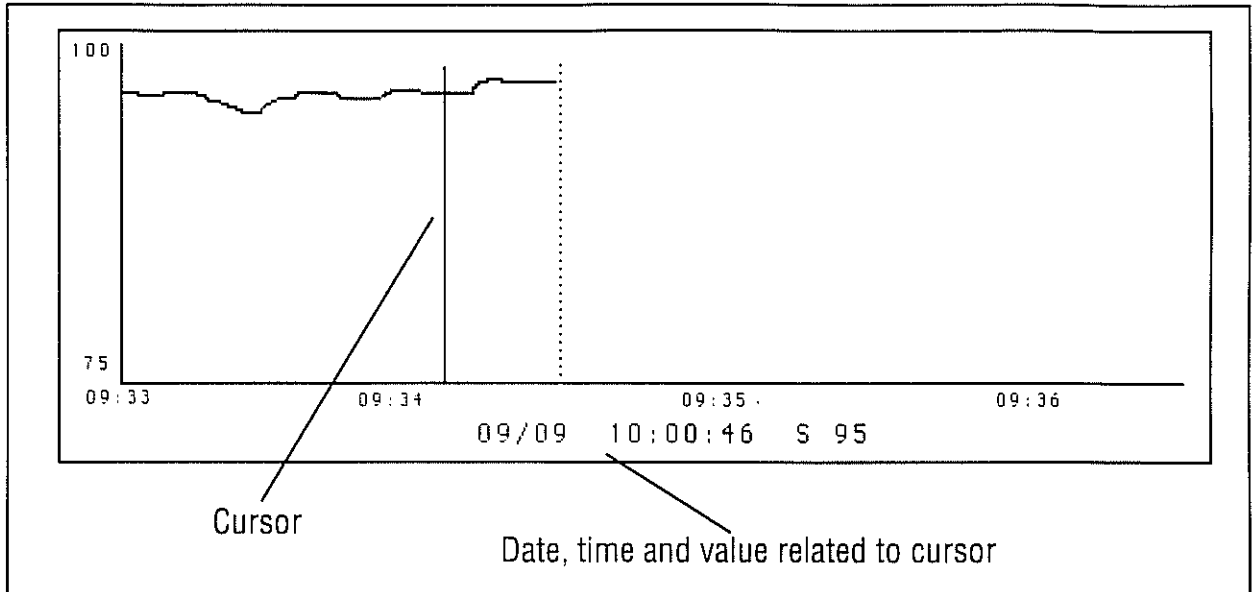

Moving the cursor to the left of the screen causes the screen to scroll if data exists beyond the screen boundaries.

A maximum of eight trends may be retained in memory. If a ninth trend appears, the first trend is erased. By using the ▼ and ▲ keys, the cursor can access all of the trend screens in memory.

If the unit is turned on or off for less than 30 seconds, no trend is stored in memory even if data is generated.

EVENT

The EVENT key is used to mark an event (such as the beginning of oxygen or drug therapy) on the trend screens. The event marker is a dotted vertical line. To place an event marker on the trend screens, press EVENT while in any screen.

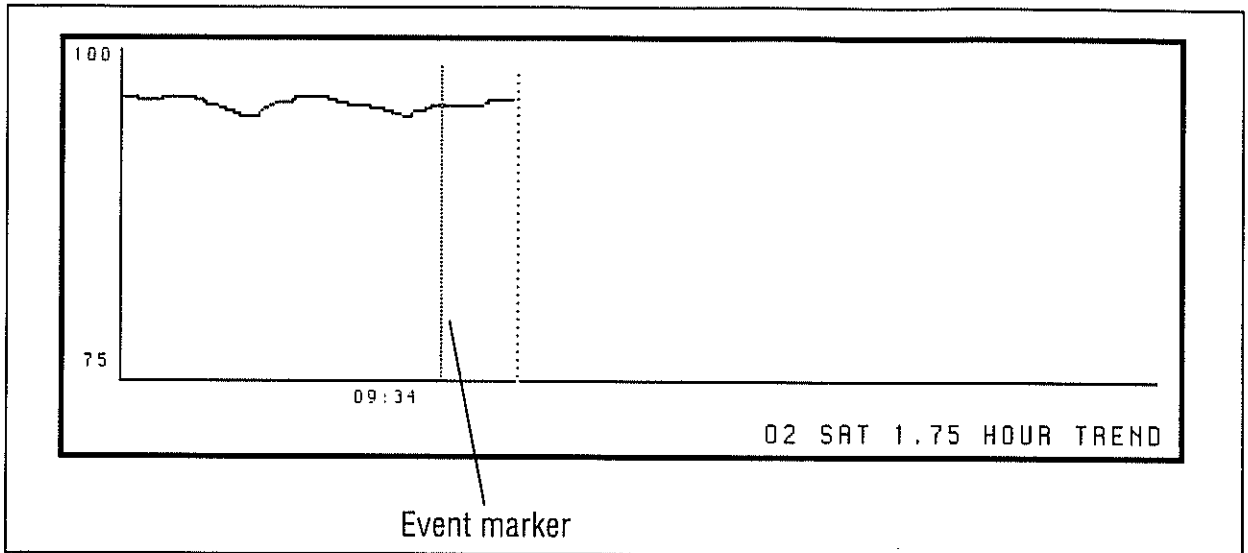

Any violation of pulse or oxygen saturation alarm limits is noted on the TREND screen as a narrow line along the horizontal (time) axis of the trend graph.

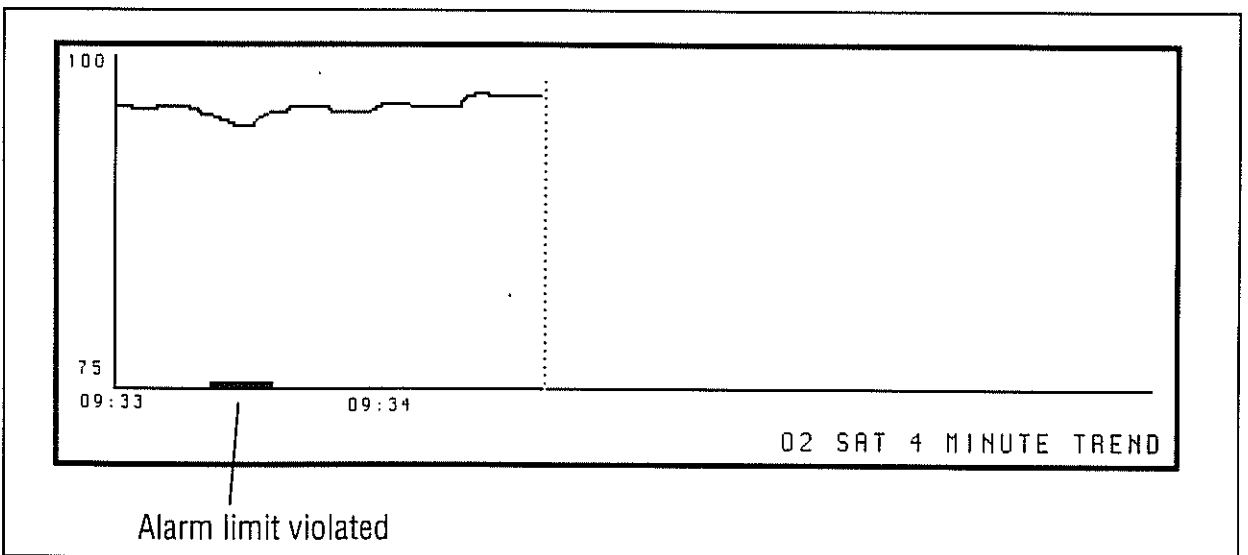

If the unit is powered off and then powered back on, the new trend will be separated from the old trend by a column of diamonds. The magnified trend screens will be separated. If there appears to be no data on the magnified trend, press TREND to expand the full screen.

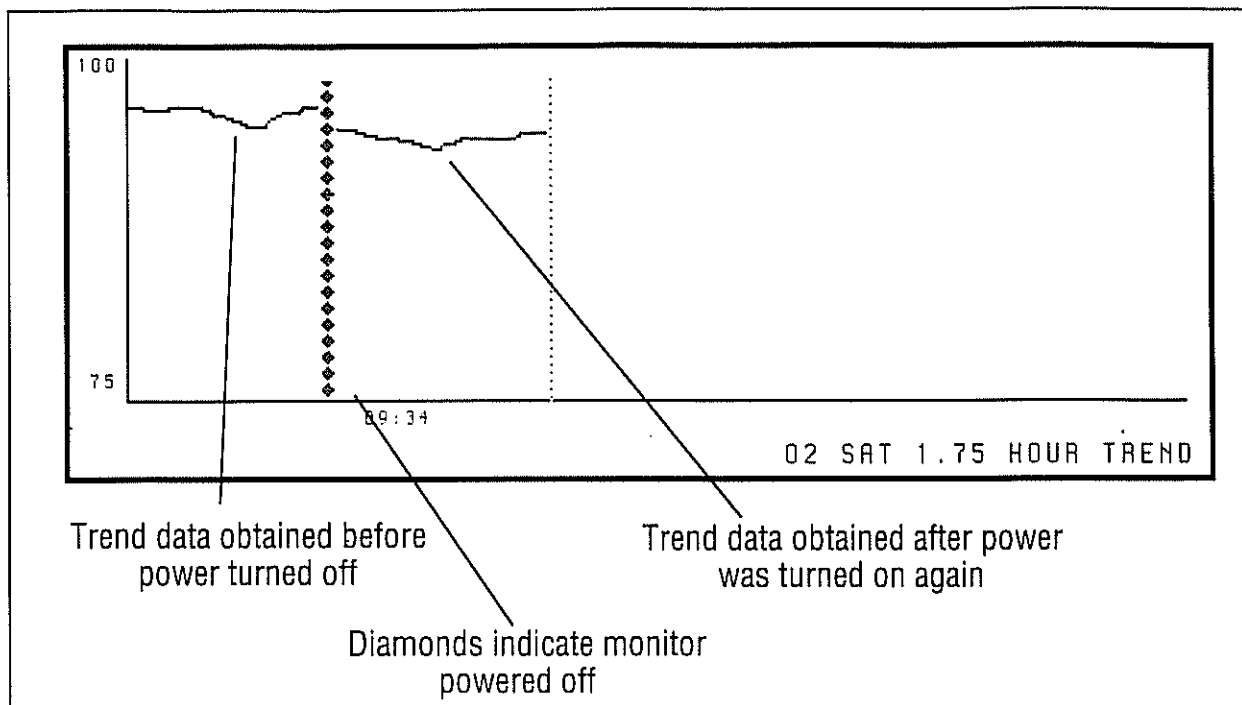

To exit the TREND display, press any other screen display switch.

NOTE

The EVENT key acts as "print" key when ASCII PRINTER, GRAPH 1 PRINTER, or GRAPH 2 PRINTER have been selected in configuration screen. *An event marker is also placed on the trend screens when one of these modes is printed.*

NOTE

The trend memory may be cleared at any time by holding the TREND key while powering on the 504 monitor.

INTEGRAL PRINTER

The 504P and 504-USB are equipped with an integral thermal printer. To print any waveform or trend screen, press the PRINT key on the top of the unit while that screen is displayed.

To advance the paper, press FEED. Do not press FEED while the printer is printing.

Examples of screen printouts using the integral printer:

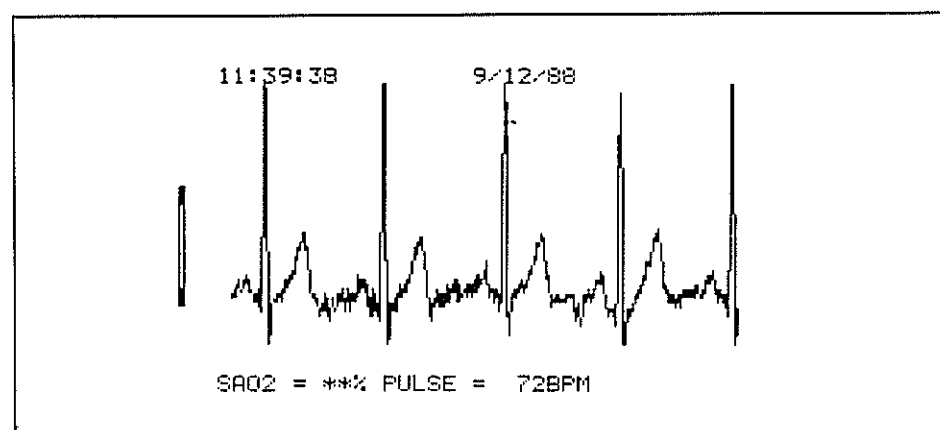
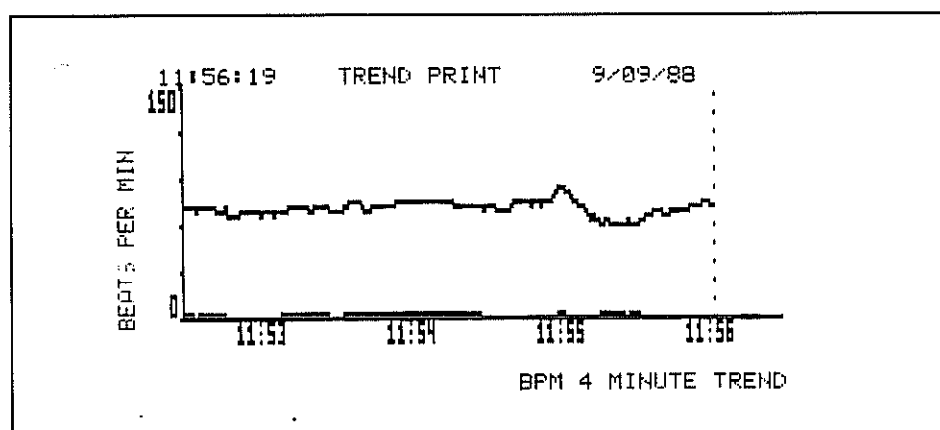
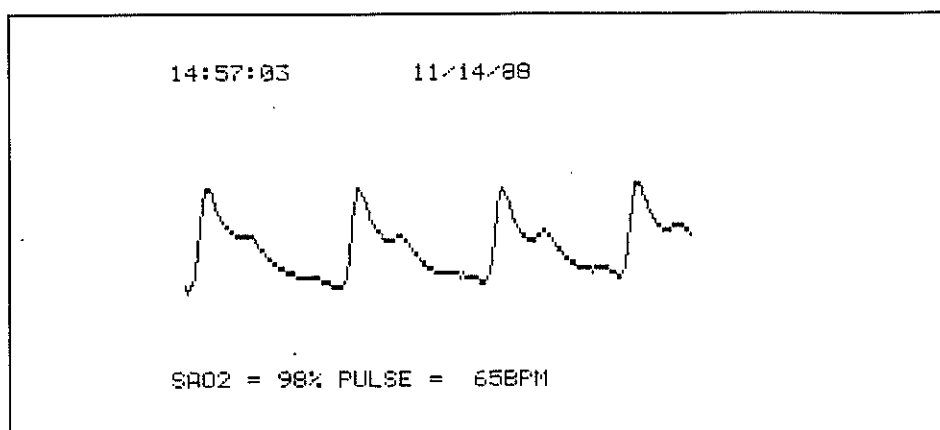

The oxygen saturation and pulse rate values may be printed out at selected intervals from 5 seconds to 99 minutes (in 5 second increments). Access the Alarm Menu screen. Set the Interval Print to the appropriate minutes and seconds by using the ▲/▼ keys. Note: 0 minutes and 0 seconds is the demand print only setting. Press the PRINT key to begin printing.

CRITICARE SYSTEMS INC.		
INTERVAL PRINT		
9/12/88		
PRINT START - 15:47:09		
PRINT INTERVAL: 0 MIN		
10 SEC		
TIME	PULSE	SAO2%
15:47:18	61	99
:28	56	99
:38	58	99
:48	58	99
:58	57	99
:48:08	57	99
:18	55	99
:26	69*	99
:36	80*	99
:46	66*	99
:56	59	99
:49:06	63	99
:16	61	99

To turn interval printing off, set both the minutes and seconds to 0. The set Interval Print parameter remains in memory when the unit is turned off; pressing PRINT will re-initiate interval printing when the monitor is powered on.

LOADING PRINTER PAPER

- Open the printer cover and remove the paper spindle.
- Cut the new paper evenly across.
- Place the paper roll on the spindle so the paper feeds from the bottom of the roll.
- Turn the monitor on.
- Feed the paper into the printer slot while pressing FEED.
- When paper grabs and is visible at the top of the printer, stop pressing FEED.
- Set paper with spindle into the brackets in the paper chamber.

NOTE

DO NOT pull the paper backwards out of the printer. Doing so may damage the printer.

INTERFACING THE 504 WITH EXTERNAL DEVICES

To interface your CSI monitor to a computer or a printer, it is necessary to match all of the parameters on the monitor and the computer, or printer.

These parameters are:

- Baud rate (the speed at which information is transferred from the monitor);
- Protocol (the manner in which data is transferred);
- Number of data bits (7 or 8);
- Parity (none, odd, even);
- Stop bit (present or not); and
- Mode (the way that the data received is handled).

INTERFACING TO AN EXTERNAL PRINTER

The 504 series monitors are designed to use *Serial* (RS-232C) ASCII printers with Epson MX graphics emulation. Printers that support this graphics mode include: the Epson FX series; the Hewlett-Packard ThinkJet; and Diconix 150 S. If the printer supports ASCII printing but not the FX graphics mode, it is still possible to print text data (the ASCII format) from the 504 monitor.

Pinouts for Computer Interface

PIN	SIGNAL
2	RS-232 OUT
3	RS-232 IN
7	COMMON
22	RS-422 OUT (-)
23	RS-422 OUT (+)
24	RS-422 IN (+)
25	RS-422 IN (-)

Serial Cable Description

504 PIN#	PRINTER PIN#
2	3
3	2
7	7
CONNECTOR	CONNECTOR
Male DB-25	Male DB-25

The printer must be connected to the 504 with the appropriate cable. Most serial printers will use a standard *Serial* printer cable. However, first check the printer manual for the "pinout". Look for:

PIN 2 RS-232 IN (receives data from the monitor here)
PIN 3 RS-232 OUT (transmits data to the monitor here)
PIN 7 COMMON (or GROUND, or SIGNAL GROUND, SERIAL GROUND, etc.)

If the printer does not use these pins, a custom cable is required.

CSI equipment does not support hardware handshaking (RTS, CTS). It is not possible to use a printer that requires hardware handshaking.

SETTING PARAMETERS ON THE EXTERNAL PRINTER

BAUD RATE

Set the baud rate at the highest number that BOTH the monitor and printer support. The 504 monitor supports baud rates of 300, 1200, 2400, 4800, 9600 and 19200 (sometimes written 19.2K) baud. The baud rate **MUST** be set the same on both the 504 and the printer. Therefore, if the printer can go up to 9600 baud set both the 504 and printer to 9600 baud.

PARITY

The 504 does not send parity bits. Set the printer for "no parity".

STOP BITS

The 504 transmits 1 stop bit. Some older printers require 2. Most printers do not allow any alteration of this setting. If possible, set the printer to accept only 1 stop bit.

DATA BITS

The 504 sends 8 data bits. Set the printer to accept 8 data bits.

HANDSHAKE MODE

CSI monitors use the XON/XOFF (pronounced "X on, X off") mode. Set the printer to accept XON/XOFF (or DC1/DC3) data.

SETTING PRINTING PARAMETERS ON THE 504

These parameters are selected on the Configuration Screen.

BAUD RATE

Set the baud rate to the highest rate that the printer and monitor can handle. The 504 monitor supports baud rates of 300, 1200, 2400, 4800, 9600 and 19200 (sometimes written 19.2K) baud.

SERIAL INTERVAL

This sets the interval at which the 504 sends data to the printer. Selectable intervals are: OFF (demand printing by pressing the EVENT key only) and TREND (see explanation following), 1, 2, 5, 10, 20, and 30 seconds, 1, 2, 3, 4, 5, 6, 8, 10, 15, 20, and 30 minutes, 1, 2, 4, and 8 hours. *Serial intervals of less than one minute cannot be selected for either GRAPH 1 or GRAPH 2 PRINTER.*

The TREND interval setting prints out a trend screen to the printer when the trend screen is 75% full. This makes a paper trend record available. A graphics mode (GRAPH1 PRINTER or GRAPH 2 PRINTER) must be selected in the SERIAL FORMAT parameter in order for this feature to work.

SERIAL FORMAT

The formats applicable for printing on an external printer are:

ASCII PRINTER

```
13:11:00 02 Sat = 99% : Pulse Rate = 64 BPM
          05 02 Sat = 99% : Pulse Rate = 66 BPM
          10 02 Sat = 99% : Pulse Rate = 70 BPM
          15 02 Sat = 99% : Pulse Rate = 71 BPM
          20 02 Sat = 99% : Pulse Rate = 72 BPM
          25 02 Sat = 99% : Pulse Rate = 80 BPM
          30 02 Sat = 99% : Pulse Rate = 80 BPM
          35 02 Sat = 99% : Pulse Rate = 80 BPM
          40 02 Sat = 99% : Pulse Rate = 79 BPM
          45 02 Sat = 99% : Pulse Rate = 76 BPM
          50 02 Sat = 99% : Pulse Rate = 70 BPM
          52 02 Sat = 99% : Pulse Rate = 69 BPM
          55 02 Sat = 99% : Pulse Rate = 69 BPM
          55 02 Sat = 99% : Pulse Rate = 69 BPM
          59 02 Sat = 99% : Pulse Rate = 68 BPM
13:12:00 02 Sat = 99% : Pulse Rate = 65 BPM
```

GRAPH 1 PRINTER:

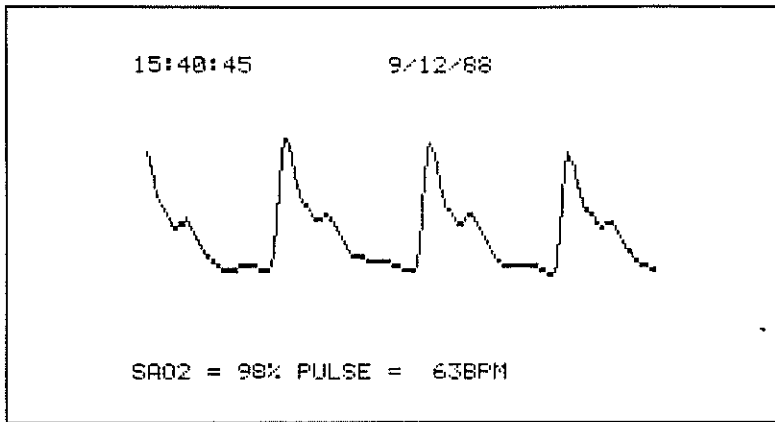

GRAPH 1 PRINTER prints the waveform or trend screen and the current oxygen saturation, pulse rate and time.

GRAPH 2 PRINTER:

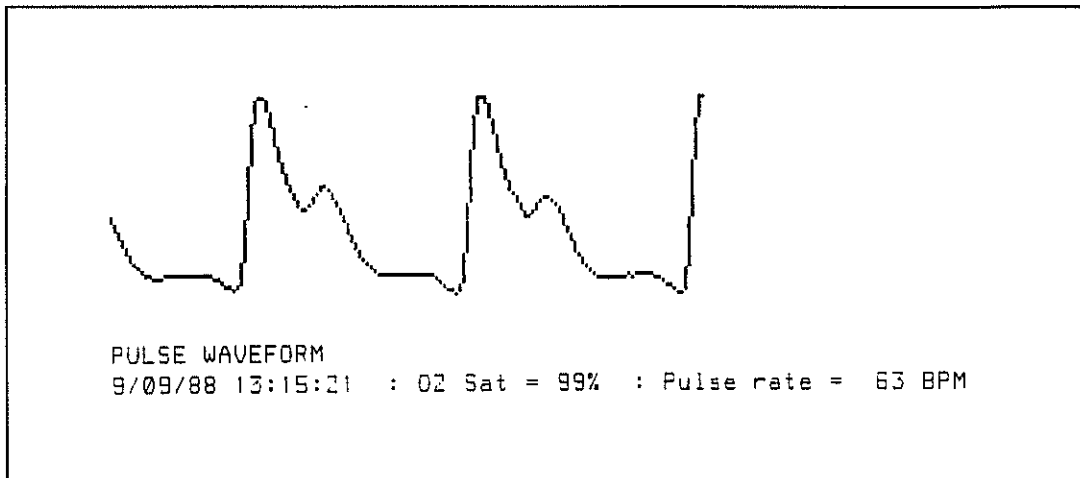

GRAPH 2 PRINTER is a larger version of GRAPH 1 PRINTER.

PRINTING GRAPHICS

The 504 can print the current screen display using an external serial graphics printer that is Epson-compatible, such as a Diconix 150 S, an HP ThinkJet, or Epson printer.

Select a graphics printing mode in the Serial Format parameter on the 504's Configuration Screen (GRAPH 1 PRINTER or GRAPH 2 PRINTER). Set the SERIAL INTERVAL parameter to the desired printing interval. Exit to the WAVEFORM or TREND screen that is to be printed. The screen displayed is printed out on the printer at the specified serial interval.

The EVENT key also acts as a "print on demand" key. The printer prints the displayed waveform or trend screen whenever EVENT is pressed.

The other formats (ASCII TREND, DIF TREND, BINARY TREND) are used for transmitting trend data to computers. See the *Interfacing to an Computer* section for more information.

PRINTING ASCII DATA

To print ASCII data, select ASCII PRINTER as the SERIAL FORMAT in the Configuration Screen. Set the SERIAL INTERVAL to the selected time. Exit the Configuration Screen by selecting the waveform or trend screen. The printer will print ASCII data at the selected interval.

The following is an example of printed ASCII data from a 504 monitor:

21	02	Sat = 98%	:	Pulse Rate = 68	BPM
22	02	Sat = 98%	:	Pulse Rate = 69	BPM
23	02	Sat = 98%	:	Pulse Rate = 69	BPM
23	02	Sat = 98%	:	Pulse Rate = 69	BPM
24	02	Sat = 98%	:	Pulse Rate = 69	BPM
25	02	Sat = 98%	:	Pulse Rate = 69	BPM
26	02	Sat = 98%	:	Pulse Rate = 68	BPM
27	02	Sat = 98%	:	Pulse Rate = 67	BPM
27	02	Sat = 98%	:	Pulse Rate = 67	BPM
28	02	Sat = 98%	:	Pulse Rate = 67	BPM
29	02	Sat = 98%	:	Pulse Rate = 69	BPM
30	02	Sat = 98%	:	Pulse Rate = 73	BPM
30	02	Sat = 98%	:	Pulse Rate = 75	BPM

The EVENT key also acts as a "print on demand" switch: the printer will print the current values whenever EVENT is pressed.

INTERFACING TO A COMPUTER

To connect a CSI monitor to a computer, match the parameters between the computer and the monitor, as previously described. Note that the cable will be different from a printer cable.

The modes applicable for PC interfacing are: ASCII TREND and BINARY TREND. ASCII TREND outputs the entire trend memory to the computer in the ASCII format.. BINARY mode transmits trend data quickly.

ASCII TREND

The ASCII format consists of one line for each trended point. A carriage return (<ASCII 13> or <CR>) and line feed (<ASCII 10> or <LF>) sequence terminates each line. Data fields are separated by commas. If a value is not obtained due to SENSOR, or another error condition, it is replaced with asterisks.

If the selected trend resolution is 1.75 , 3.5, or 8.75 hour format that displays an average rather than a minimum and maximum value, the minimum and maximum fields will be the same.

A < control-Z> (<ASCII 26>) marks the end of file.

The last field is an event/alarm field which uses single characters to mark the following events:

- * Event marker placed by operator
- S Saturation alarm limit violated
- P Pulse rate alarm limit violated

FORMAT:

MM/DD/YY HH:MM:SS, SATMIN, SATMAX, BPMMIN, BPMMAX, (*SP)

EXAMPLES:

```
3/29/88 2:03:30, 89, 97, 65, 78, *S <CR> <LF>
3/29/88 2:03:30, **, **, ***, ***, <CR> <LF>
3/02/88 12:05:00, 98, 98, 124, 124, P<CR> <LF>
```

To transmit the trend data, access the Configuration Screen. Select ASCII Trend as the Serial Format. Press EVENT while in the Configuration Screen. To cancel the transmission, press EVENT again.

Trend dumps can also be initiated remotely via the RS 232 Link. To initiate a trend dump, send 'd' or 'D' <CR> to the 504. To abort, send 'd' or 'D' <CR> again.

BINARY FORMAT

A binary trend output format is provided for increased transmission speed. A 12-byte binary record is used for each stored point. The end of file is signified by an all-zero (00000000) record. The bit order in status bytes is 76543210 (high = 7, low = 0).

Binary Format:

Bytes 0–5:	Month Day Year Hour Minute Second
Bytes 6–9:	Sat (min), Sat (max), BPM (min), BPM (max) If no data was collected, values are set to 0
Byte 10:	A status byte, with bit flags as follows: Bit 0: If 1, saturation alarm was violated Bit 1: If 1, no saturation data collected Bit 2: If 1, pulse rate alarm was violated Bit 3: If 1, no pulse rate data collected
Byte 11:	A status byte, with bit flags as follows: Bit 7: If 1, user marked an event

To transmit the trend data, access the Configuration Screen. Select Binary Trend as the Serial Format. Press EVENT while in the Configuration Screen. To cancel the transmission, press EVENT again.

INTERFACING TO A STRIP-CHART RECORDER

The 504 has two analog outputs for use with strip-chart recorders and oscilloscopes. The connectors on the rear panels are BNC type, and are labeled CH. A and CH. B. The following modes for both ANALOG CHANNEL A and ANALOG CHANNEL B are selected in the configuration screen:

MODE	OUTPUT
TEST MODE	See below
ECG WAVE	Electrocardiograph
PULSE WAVE	Plethysmograph
O2 SAT 0-100%	Output: 0-1 VDC
O2 SAT 50-100%	Output: 0-1 VDC
PULSE RATE 0-250 bpm	Real Time Trend 0-1 VDC

Both channels may be set to any output. The output of a channel changes immediately after the output type selected is changed in the Configuration Screen.

TEST MODE

To confirm calibration, attach a voltmeter to the BNC connector output. Output will rise to 1.0 VDC at the end of the test cycle. The voltage increases in steps of 0.1 volt every 0.5 sec, rising to 1.0 volts, as shown:

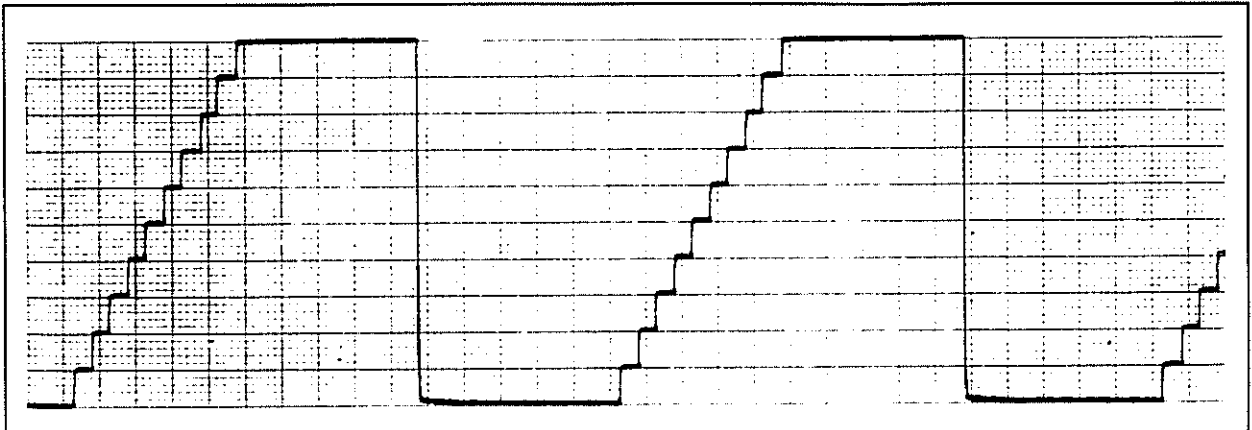

ECG WAVE

The analog ECG is output:

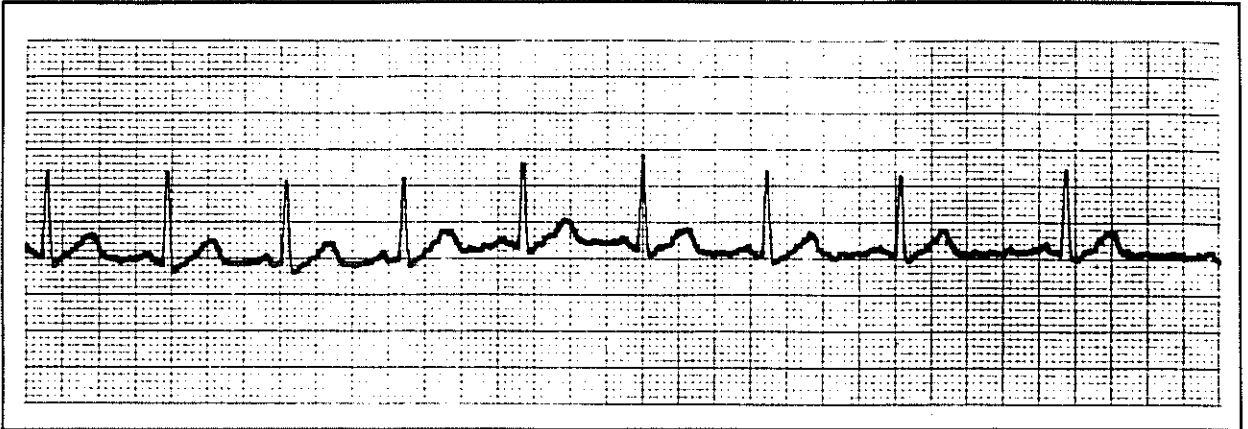

PULSE WAVE

The analog pulse waveform is output:

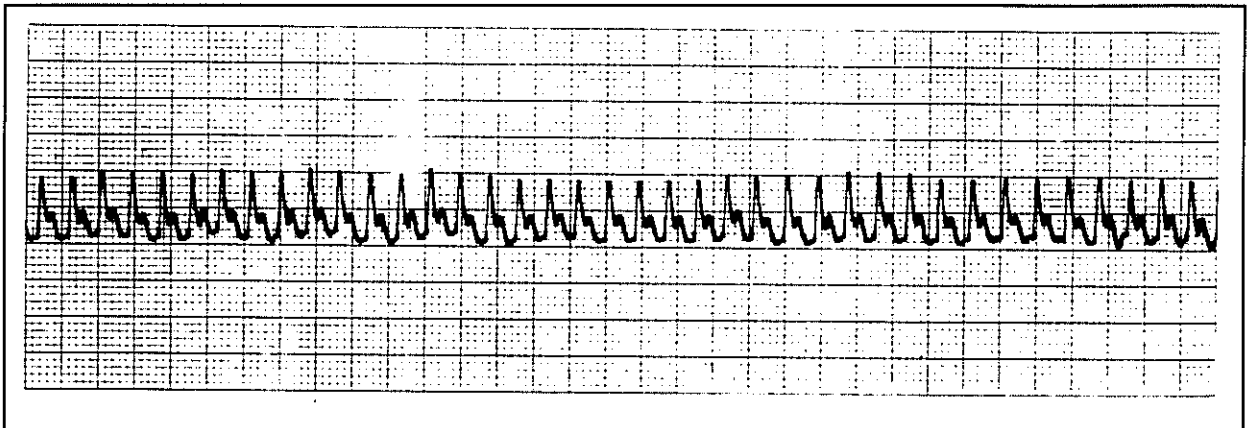

SATURATION 0-100 (Oxygen Saturation 0-100%)

The output in VDC corresponds to the following chart:

O2 SAT 0-100	VDC
100	1.00
99	0.99
98	0.98
97	0.97
96	0.96
.	.
.	.
0	0.00

SATURATION 50-100 (Oxygen Saturation 0-100%)

The output in VDC corresponds to the following:

O2 SAT 50-100	VDC
100	1.00
99	0.98
98	0.96
97	0.94
96	0.92
.	.
.	.
0	0.00

PULSE RATE

The output in VDC corresponds to the following:

BPM	VDC
250	1.00
245	0.98
240	0.96
235	0.94
230	0.92
.	.
.	.
0	0.00

PULSE RATE and O₂ SAT 50-100% or 0-100% allow for trending on strip-chart recorders.

MAINTENANCE AND CLEANING

CAUTION

Turn power off and disconnect from AC power before cleaning the monitor and sensor. Never immerse the monitor or any CSI sensor in liquids.

The exterior surfaces of the 504 and sensors may be wiped clean using alcohol and dried with a clean, dry cloth. The photodetector and LED's in the sensors may also be cleaned with alcohol.

The ECG cable and leads may be cleaned with alcohol.

Do not use abrasive cleaners on the front panel as they may mar the surface.

There are no user serviceable parts inside the monitor. Do not remove the cover. Refer all servicing to a qualified technician.

The rechargeable battery is a sealed lead acid type battery and is totally maintenance free. If the battery becomes defective, only a service technician should replace it.

DO NOT USE ABRASIVE CLEANERS

DO NOT AUTOCLAVE THE SENSORS

Check the ECG lead wires and cables, sensor cables and power cords periodically for frays and cracks. Discard if frays or cracks are present.

If the monitor shows any signs of physical damage which may affect its function, return it to the CSI Service Department for repair.

If the connector on any extension or cable inadvertently gets wet, flush the connector with distilled or deionized water and dry in a 40-80° C environment for at least one hour.

The 517 Multi-Site Sensor paddles may be disinfected with a 2% gluteraldehyde solution. Do not immerse the telephone connector in the solution.

The following performance and safety checks should be done semi-annually by a qualified service technician:

1. Complete function testing of the system as found in the final test procedure of the 504 Service Manual.
2. Electrical leakage test to the monitor and recharging unit.

STATUS MESSAGES

ALARM OFF

Displays whenever the alarm volume is disabled (set to zero).

ALARM SIL

Displays whenever the alarms are temporarily silenced.

HI AMBIENT

Indicates a large amount of ambient light or noise is being detected. Shield the sensor from outside light sources such as sunlight, infrared heaters and bilirubin lights.

LO BATTERY

Indicates approximately 1 hour of continuous operation remaining. If battery power falls below levels consistent with reliable operation, the unit will automatically turn off.

LOSAT OFF

Displays whenever the Low Saturation alarm is set to OFF and the audible alarm is not silenced or disabled.

LRN

Indicates the smart alarm mode has been activated.

SEARCH

Indicates pulse is too weak or erratic to make accurate saturation and pulse determinations. Move sensor to an area with better perfusion.

SENSOR

Too much light is being transmitted through the current site. Select a site with greater tissue thickness or density. SENSOR can indicate the sensor has fallen out of place, check positioning.

SENSOR SGNL

- Indicates tissue at the monitoring site is too thick to allow light to penetrate. Move the sensor to another location.
- Indicates the sensor is not attached to the monitor. Check the monitor to assure proper sensor connection.
- Indicates a sensor malfunction. Hold the sensor so the LED's and photodetector face each other. Cover the photodetector, then uncover it. There should be a change in the intensity of the red LED's. If there is no change in intensity, or if the LED's emit light intermittently, there is a sensor malfunction. If you have a sensor malfunction, contact the CSI Customer Service Department for assistance.

Note: If HI AMBIENT, SENSOR or SENSOR SGNL display for five minutes, the monitor automatically turns itself off.

SYSTEM FAULT

Signifies a monitor or option fault. The error displays below the System Fault message:

RAM TEST FAILED	ROM CHECK SUM FAIL
RTC FAIL	LCD FAIL
ILLEGAL VALUE	ADC FAIL
INVALID VALUE	

Refer servicing to a qualified service technician.

ULTRASYNCTM STATUS MESSAGES

ECG

Indicates detection of the ECG signal.

ECG LOST

Indicates QRS complexes are no longer being detected.

LEAD OFF

Indicates one of the ECG leads is loose or has fallen off the patient.

SYNC

Indicates pulse waveform measurements have been synchronized with the ECG.

UNPACKING AND INSPECTING THE EQUIPMENT

Confirm that the following are included in the shipment you receive from the factory:

504 Monitor Type:	504	504P	504-US	504-USP
511 Finger Sensor:	✓	✓	✓	✓
or				
516 Multi-Site Sensor Package	✓	✓	✓	✓
538 ECG Cable (AAMI)			✓	✓
539 Lead Wires - safety (3)			✓	✓
539R Red lead wire			✓	✓
539B Black lead wire			✓	✓
539W White lead wire			✓	✓
553 Printer Paper (3 rolls)		✓		✓
587 Operator's Manual	✓	✓	✓	✓
902 AC Charger-120 VAC	✓	✓	✓	✓
or				
905 AC Charger-220/240 VAC	✓	✓	✓	✓

If any component is missing or damaged, contact the CSI Customer Service Department at 1 (800) 458-4615.

504/504-US SERIES ACCESSORIES

CAT #	DESCRIPTION
511	Oxygen Saturation Sensor (Adult Finger Sensor)
513	Forehead Applicator and Headband
514	Earclip Attachment
516	Multi-Site Sensor Package, <i>including:</i> Sensor Patient Cable Earclip, Adhesive Dots Forehead Applicator, Headband
517	Multi-Site Sensor only
518	Patient Cable only
522	I.V. Pole Clamp (504/504-US)
525	Double-Sided Adhesive Dots
526	Tape - Microfoam (4" strips, 14 per package)

527	Electrodes - Disposable
538	ECG cable (AAMI)
539B	ECG Lead - Black
539R	ECG Lead - Red
539W	ECG Lead - White
546	High level auxiliary input cable for HP monitors
547	High level auxiliary input cable for Spacelabs and Tektronics monitors

553	Printer Paper (504/504-US)
570	Adult Disposable Sensor (25 mm)
571	Pediatric Disposable Sensor (20 mm)
572	Infant Disposable Sensor (20 mm)
573	Neonatal Disposable Sensor (25 mm)
574	Disposable Sensor Variety Pack
587	Operator's Manual (504/504-US)
597	Service Manual (504/504-US)
902	AC Charger, 120 VAC, 60 Hz
905	AC Charger, 220/240 VAC, 50 Hz

SPECIFICATIONS

% O₂ SATURATION:

Range: 0-100%
Resolution: 1%
Accuracy: 70-100%, ±2%
50-70%, ±3%
<50%, unspecified

PULSE RATE:

Range: 20-250 BPM
Resolution: 1 BPM
Accuracy: ± 1% full scale

ECG:

Input: Lead II
Input Impedance: > 10M ohms
Leakage Current: < 5 micro amps
Frequency Response: 5 to 40 Hertz

HIGH SATURATION ALARM:

Range: Off, 70-99%
Resolution: 1%

LOW SATURATION ALARM:

Range: Off, 1-99%
Resolution: 1%

HIGH PULSE RATE ALARM:

Range: Off, 80-250 BPM
Resolution: 1%

LOW PULSE RATE ALARM:

Range: Off, 20-160 BPM
Resolution: 1 BPM

DISPLAYS:

Backlit Dot Matrix LCD
7 segment .56" and .30" LED

POWER REQUIRED:

902 Charger: 120 VAC, 60 Hz 6.5 Watts (Max)/11 VAC, 500 mA
905 Charger: 220/240 VAC, 50 Hz 7.5 Watts (Max)/11 VAC, 600 mA

SHOCK PROTECTION:

TYPE BF: Models 504/504P TYPE CF: Models 504US/504 USP

BATTERY:

Sealed Lead Acid, 6V @ 4A Hr. 10 hour life (minimum) on full charge.

RECHARGE TIME:

10 hours (power off)

DIMENSIONS:

3.5"H x 10"W x 8"D (8.9 x 25.4 x 20.3 cm)

WEIGHT:

6.5 lbs. (2.9 Kg)

SENSOR TYPE:

Dual Wavelength LED

CABLE LENGTH:

10 feet standard

CLOCK/CALENDAR:

24 Hours: Hours: Minutes: Seconds
365 Day: Month:Day:Year

WARRANTY

Criticare Systems, Inc. (CSI) warranties new equipment other than the 517 Multi-Site Sensor to be free from defects in workmanship and materials for a period of one (1) year from date of shipment under normal use and service. The 517 Multi-Site Sensor carries a 90 day warranty. CSI's obligation under this warranty is limited to repairing or replacing, at CSI's option, any part which upon CSI's examination proves defective.

THIS WARRANTY IS EXPRESSLY IN LIEU OF, AND CSI MAKES NO OTHER WARRANTIES, EXPRESS OR IMPLIED, INCLUDING WARRANTIES OF MERCHANTABILITY OR FITNESS FOR ANY PARTICULAR PURPOSE.

CSI's obligation or liability under this warranty does not include any transportation or other charges or liability for direct, indirect or consequential damages or delay resulting from any defect. Any operation beyond rated capacity or the improper use or application of the product of the substitution upon it of parts or accessories not approved by CSI or repair by anyone other than a CSI authorized representative shall void this warranty.

This warranty does not extend to any instrument which has been subjected to misuse, negligence or accident; any instrument from which CSI's original serial number tag or product identification markings have been altered or removed; or any product of any other manufacturer.

Criticare Systems, Inc. is responsible for the effects on safety, reliability and performance of the 504 Series Monitor only if:

- Assembly operations, extensions, re-adjustments, modifications or repairs are carried out by persons authorized by Criticare Systems, Inc., and
- the 504 Series Monitor is used in accordance with the instructions for use, and
- the electrical installation of the relevant room complies with the 'Regulations for the electrical equipment of buildings' PUBLISHED BY THE INSTITUTION OF ELECTRICAL ENGINEERS.

In case of emergency contact:

CSI-USA
20900 SWENSON DRIVE
SUITE 398
WAUKESHA, WI 53186
PHONE: (414) 797-8282
TELEX: 5106012199
FAX: 797-8491

CSI-EUROPE
c/o MEDLOG GMBH
LANDGRAF PHILIPP RING 8
6380 BAD HOMBURG
WEST GERMANY
PHONE: 06172-32052
TELEX: 4181131

CSI-ASIA
OSAWA BLDG.
3RD FLOOR
3-6-9 HONGO
TOKYO 113 JAPAN
PHONE: 03-814-7051
FAX: 03-814-6508

RETURN POLICY

A 504 Service Manual (Cat. No. 597) is available for technical personnel to repair parts of the equipment which are defined as serviceable. The manual includes circuit diagrams, component parts' lists and descriptions.

In the event that it becomes necessary to return a unit to Criticare Systems, Inc., the following procedure must be followed:

1. Contact the CSI Service Department to obtain a Customer Service Authorization (CSA) number. Please provide the model number, serial number and a brief description of the reason for return.

NOTE

The CSA number must appear on the outside of the shipping container. Return shipments will not be accepted if the CSA number is not clearly visible.

2. *Freight policy.* The customer is responsible for freight charges when equipment is shipped to CSI for service (this includes customs charges). After repair, the goods will be returned via the same method by which CSI received them, at CSI's expense.
3. *Loaner service.* If it is necessary to provide a loaner system, CSI will ship a loaner by Federal Express at our expense. The loaner system must be returned within one week at the customer's expense after receipt of the repaired goods. If the unit is not returned to CSI within that time, the customer will be invoiced for the full purchase price of the equipment.

Hewlett-Packard ThinkJet (Serial Version)

CABLE

The cable used to connect the HP ThinkJet to the CSI monitor will be configured as follows:

CSI Pin #	ThinkJet Pin #
2	3
3	2
7	7

Both ends of the cable will be male DB-25 connectors. This is a standard serial printer cable. It may also be called a modem eliminator serial cable.

SERIAL PARAMETERS

BAUD RATE

The maximum baud rate (the speed at which data is transmitted) that the ThinkJet printer can be set to is 19200 baud. Set the printer to 19200 baud by setting RS-232C switch #4, to 0, which is down. Set RS-232C switch #5 to 1, which is up. Set the CSI monitor to 19200 baud as well.

DATA BITS/PARITY

The number of data bits transmitted the CSI monitors is 8, and CSI monitors do not transmit parity bits; set the ThinkJet printer to accept 8 bits with no parity by setting RS-232C switches #2 and 3 to 0, which is down.

DATA PROTOCOL

CSI monitors use the XON/XOFF protocol; set the ThinkJet printer to accept the XON/XOFF protocol by setting RS-232C switch #1 to 0 (down).

PRINTER MODE SWITCHES

Set the remaining mode switches to the following diagram:

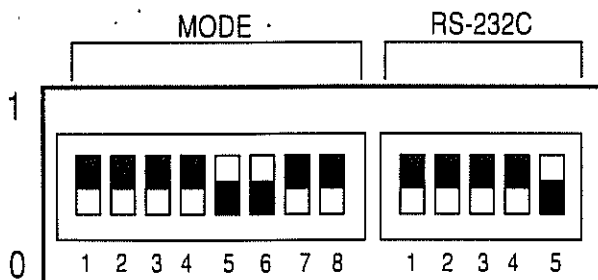

The CSI monitor will now be able to print with the ThinkJet printer after the cables have been attached and power applied to the monitor and printer.

DICONIX InkJet Printer Model 150 S

CABLE

The cable used to connect the Diconix to the CSI monitor will be configured as follows:

CSI Pin #	Diconix Pin #
2	3
3	2
7	7

Both ends of the cable will be male DB-25 connectors. This is a standard serial printer cable. It may also be called a modem eliminator serial cable.

SERIAL PARAMETERS

BAUD RATE

The maximum baud rate (the speed at which data is transmitted) that the Diconix printer can be set to is 9600 baud. Set the printer to 9600 baud by setting switches #1, #2, and #3 to 0, which is down. Set the monitor to 9600 baud as well.

DATA BITS

The number of data bits transmitted the CSI monitors is 8; set the printer to accept 8 bits by setting switch #4 to 1, which is up.

PARITY

CSI monitors do not transmit parity bits; set the Diconix printer to accept no parity bits by setting both switch #5 and #6 to 0, which is down.

DATA PROTOCOL

CSI monitors use the XON/XOFF protocol; set the Diconix printer to accept the XON/XOFF protocol by setting switch #7 to 0 (down) and switch #8 to 1 (up).

HANDSHAKE DISABLE

CSI monitors do not use hardware handshaking; set the Diconix printer to ignore all hardware handshaking by setting switches #9, 10 and 11 to 1, which is up.

SERIAL PARAMETER SWITCH SETTINGS – DICONIX MODEL 150S PRINTER

1	2	3	4	5	6	7	8
DOWN	DOWN	DOWN	UP	DOWN	DOWN	DOWN	UP

9	10	11
UP	UP	UP

PRINTER MODE SWITCHES

The Diconix printer is set for operation with CSI monitors. However, if the DIP switches are set incorrectly, or if the printer is used on other devices, then reset all of the switches to the 0, or down, position.

1	2	3	4	5	6	7	8	9
DOWN	DOWN	DOWN	DOWN	DOWN	DOWN	DOWN	DOWN	DOWN

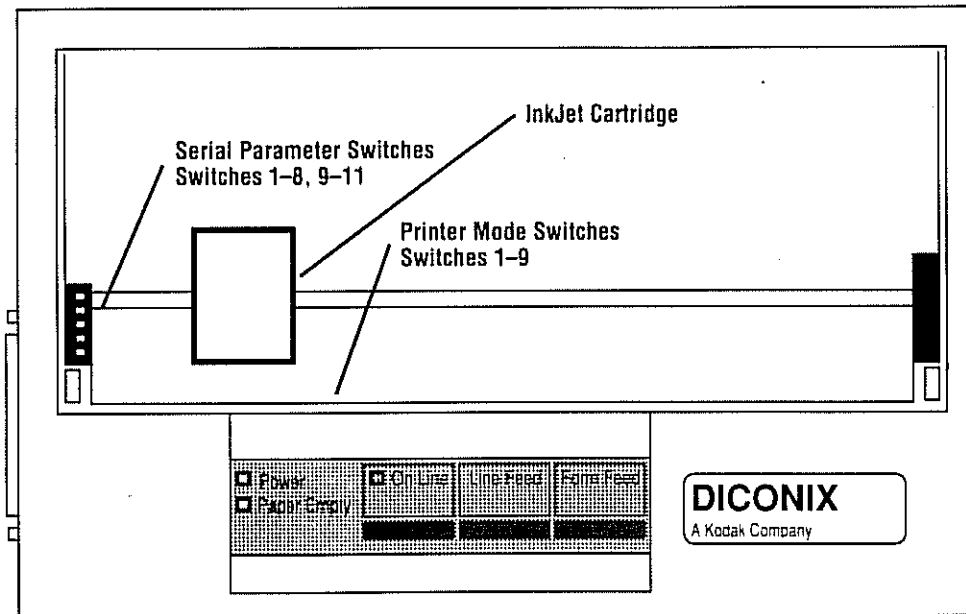

CSI to PC RS-232C Serial Interfacing

CABLE

The cable used to connect the PC to the CSI monitor will be configured as follows:

CSI #	Description	Function
PIN 2	RS-232 OUT	Transmits data to the PC here
PIN 3	RS-232 IN	Receives data from the PC here
PIN 7	COMMON	Or GROUND, or SIGNAL GROUND, SERIAL GROUND, etc.

The CSI side connector must terminate in a male DB-25 connector. The PC side may have a female DB-9 or DB-25 connector; consult the manual for the serial interface specifications and cable pinouts. Ordinarily, a DB-25 connector will be used on the PC side; in that case, connect the cable in the following fashion:

CSI #	PC Pin #	Function
PIN 2	3	Transmits data to the PC here
PIN 3	2	Receives data from the PC here
PIN 7	7	Or GROUND, or SIGNAL GROUND, SERIAL GROUND, etc.

If a DB-9 connector is used on the PC side, connect the cable in the following fashion:

CSI #	PC Pin #	Function
PIN 2	2	Transmits data to the PC here
PIN 3	3	Receives data from the PC here
PIN 7	5	Or GROUND, or SIGNAL GROUND, SERIAL GROUND, etc.

SERIAL PARAMETERS

BAUD RATE

Set the CSI monitor and the PC to send and receive data at the same baud rate.

DATA BITS/PARITY

The number of data bits transmitted the CSI monitors is 8, and CSI monitors do not transmit parity bits; set the PC to accept 8 bits with no parity.

DATA PROTOCOL

CSI monitors use the XON/XOFF protocol; set the PC to accept the XON/XOFF protocol.

DTR

If there is a DIP switch or jumper, set DTR to TRUE at all times.

TRANSMITTING TREND DATA TO THE PC

To transmit the trend data to the PC, press EVENT while in the Configuration Screen. To cancel, press EVENT again.

CONSULT YOUR SERIAL INTERFACE MANUAL FOR MORE INFORMATION.

MULTI-SITE SENSOR INSTRUCTIONS

MULTI-SITE INTENDED USAGE

The CSI Multi-Site Sensor is designed for a variety of uses. One reusable sensor is applicable for neonatal, pediatric and adult monitoring sites.

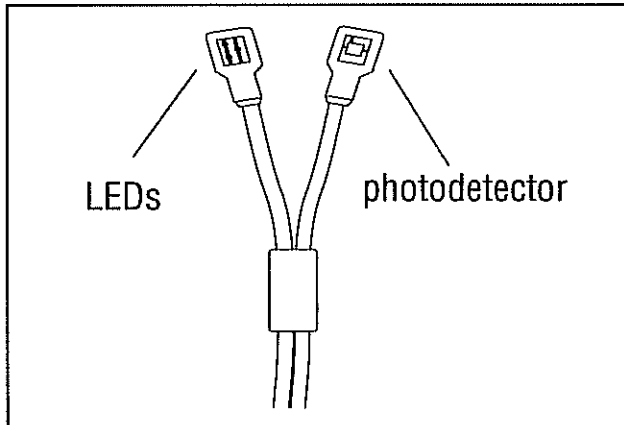

The Multi-Site Sensor has two components: LEDs and a photodetector.

CAUTION

Change the sensor site daily. Inspect the site every four to six hours. Change the site if any inflammation or skin breakdown is present. A pressure sore may result if tape has been applied too tightly.

SELECTING THE MONITORING SITE

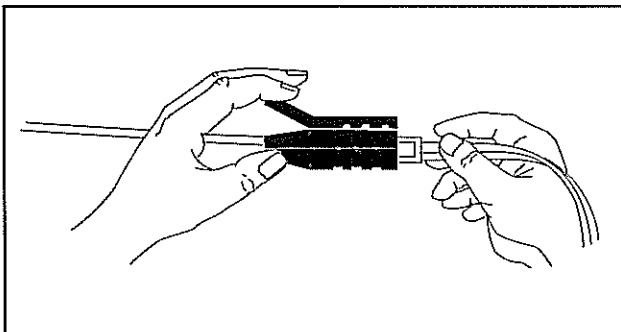

The Multi-Site Sensor is supplied in two parts: the sensor and patient cable. This permits the Multi-Site Sensor to remain taped in place on those patients who require intermittent monitoring.

Attach the Multi-Site Sensor to the patient cable as shown. Connect the cable to the CSI monitor. (To disconnect the sensor from the patient cable, first press the plastic tab, then remove the cable from the sensor.) Select the monitoring site. Tape in place according to the instructions that follow. Observe the monitor for one of the following messages:

SEARCH

Indicates the pulse is too weak or erratic to make accurate saturation and pulse determinations. Push the TEST switch and remonitor the site. If SEARCH continues to display, select another monitoring site.

SENSOR

Indicates too much light is being transmitted through the current site. Select a site with greater tissue thickness or density. SENSOR can also indicate the sensor has fallen out of place. Check the position of the sensor. Retape, if necessary.

HI AMBIENT/SGNL

Indicates interference from outside light sources such as infrared heaters or bilirubin lamps. With a cloth or other opaque material, shield the sensor from outside light sources.

SENSOR SGNL

- Indicates tissue at the monitoring site is too thick to allow light to penetrate. Move the sensor to another location.
- Indicates the sensor is not attached to the monitor. Check the monitor to assure proper sensor connection.
- Indicates a sensor malfunction. Hold the sensor so that the LEDs and photodetector face each other. Cover the photodetector, then uncover it. There should be a change in the intensity of the red LEDs. If there is no change in intensity, or if the LEDs emit light intermittently, there is a sensor malfunction. An intermittent SENSOR SGNL message during patient monitoring may indicate a sensor malfunction. *If you have a sensor malfunction, contact the CSI Customer Service Department at 1(800) 458-4615 for assistance.*



CRITICARE SYSTEMS INC.

TAPING THE MULTI-SITE SENSOR

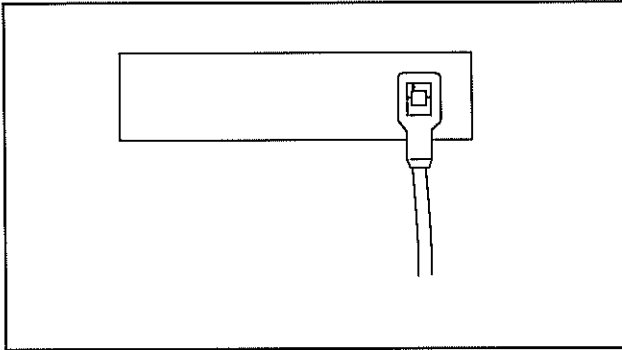

Position one paddle to the end of a piece of tape as shown above.

Secure the paddle on the extremity with the short end of the tape before positioning the second paddle. The photodetector should rest against the fleshy portion of the extremity.

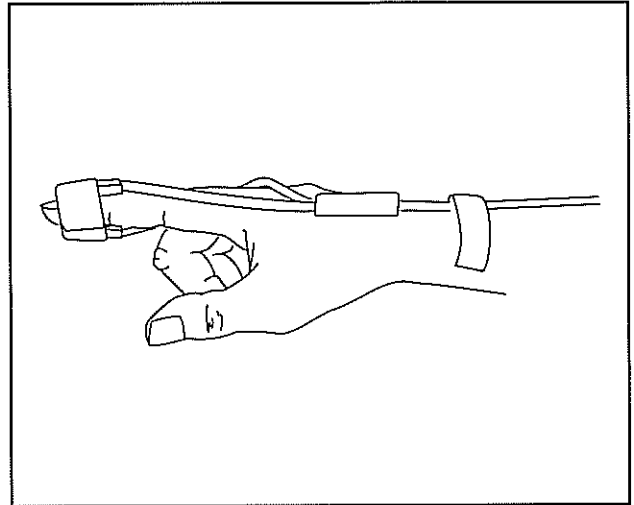

Secure the sensor cable to the extremity as shown above.

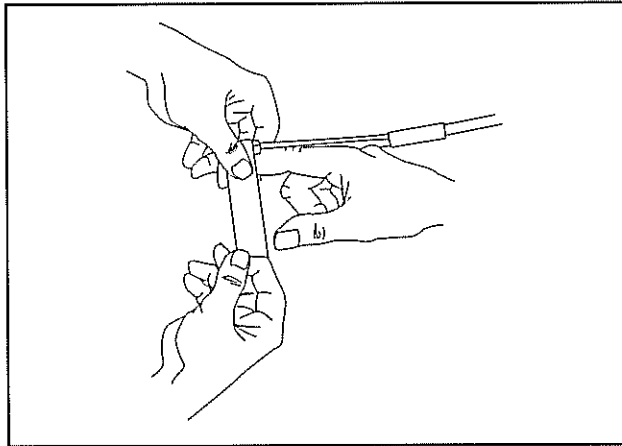

Place the second paddle on the extremity opposite the first paddle. Secure in place with the end of the tape as shown above.

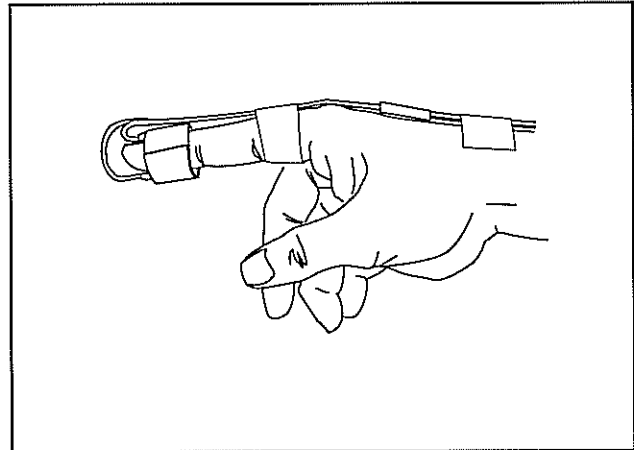

The sensor may also be applied in the opposite direction as long as it is secured to the extremity.

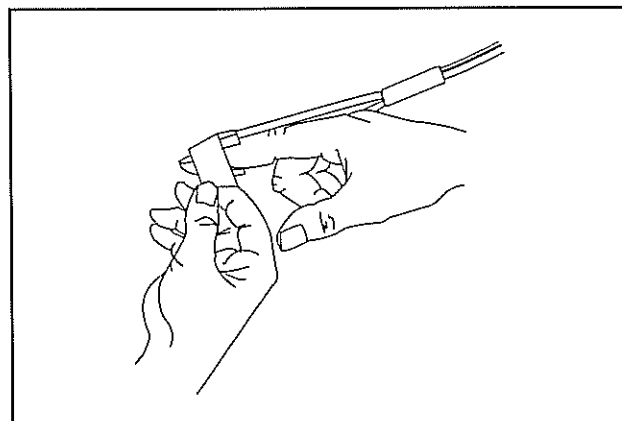

Wrap the tape around the sensor as shown above.

SELECTING MONITORING SITES

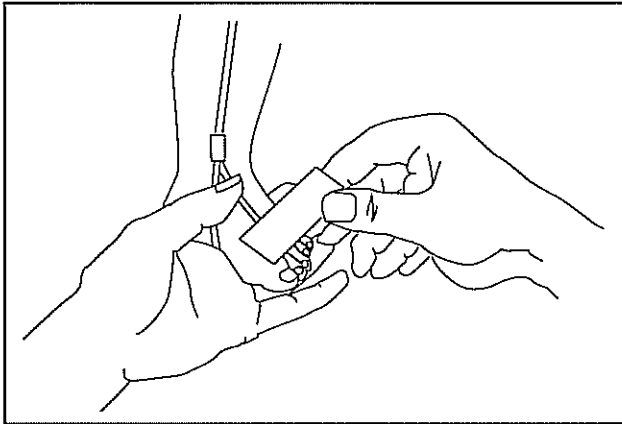

NEONATES: The preferred site for monitoring neonates and infants is the foot. However, the sensor can also be applied on the hand, wrist, ankle, or toe. Attach the Multi-Site Sensor to the foot as shown above.

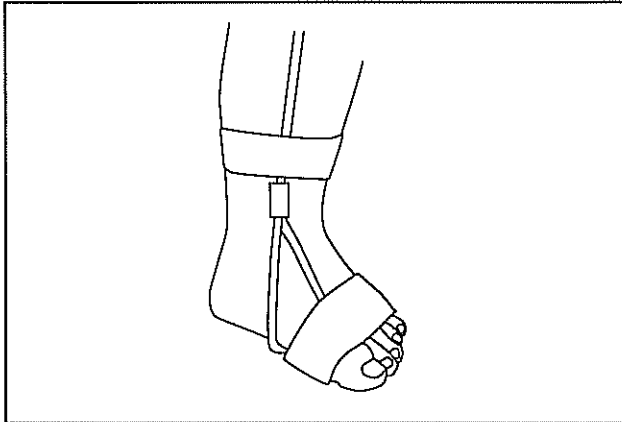

Secure the Multi-Site cable to the infant's ankle to prevent any cable strain. See above.

PEDIATRICS: Depending on the size of the child, the foot or hand may be used for monitoring. In older children, apply the sensor to the toe or finger.

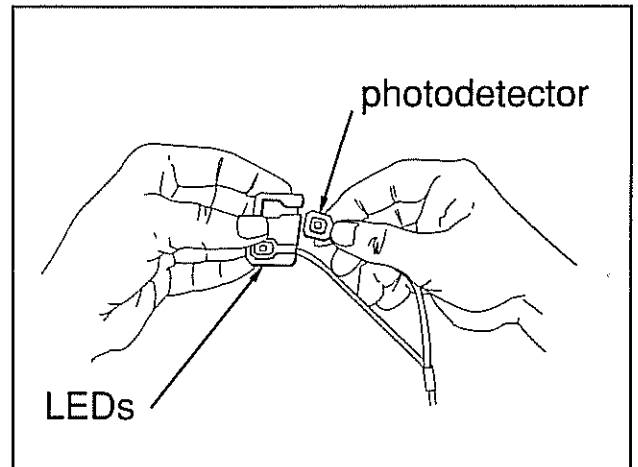

FOREHEAD: The forehead can be used as a monitoring site in adults. *Prior to placing the sensor on the forehead, wipe the area with alcohol to remove excess skin oils.* Place the Multi-Site Sensor paddles in the forehead applicator with the LEDs and photodetector facing outward as shown in the above figure. *The LEDs must be on the left and the photodetector on the right.*

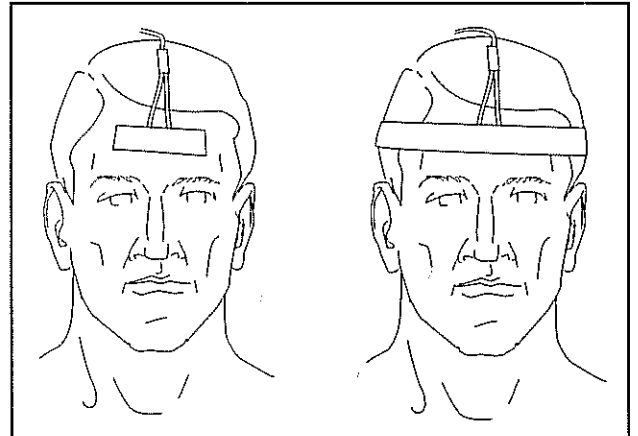

Secure in place with microfoam tape as shown above, left. To further secure the placement, position the CSI headband around the sensor and head as shown above, right.

NOTE

The Multi-Site Sensor works well on the forehead in relatively nonmobile patients. *Do not use when patient is edematous or sweating profusely.*

EARCLIP: The ear may be used as a monitoring site by placing the Multi-Site Sensor paddles in the earclip attachment.

Prior to placing the sensor on the ear, vigorously rub the earlobe for 10 to 15 seconds.

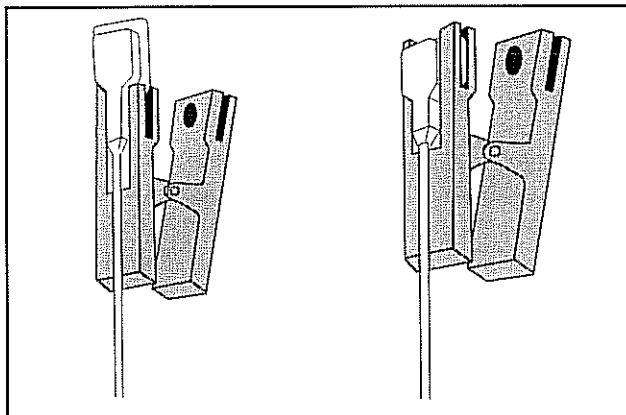

Place the sensor in the earclip as shown above. The LEDs and photodetector must face each other. Position the paddles so the photodetector and LEDs are aligned and visible through the holes in the clip. *Do not put strain on the sensor cable.*

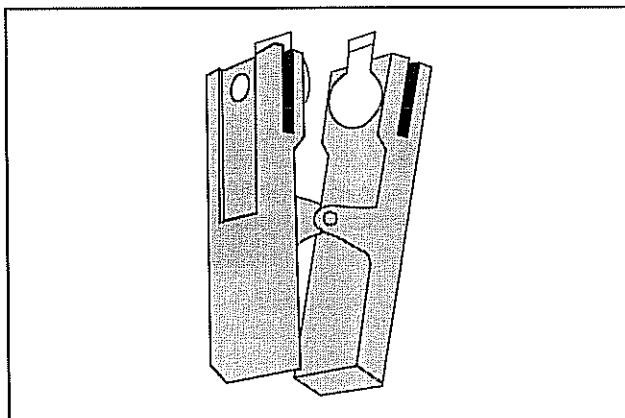

Place double-sided adhesive dots on the insides of the earclip to help secure it in place. See above.

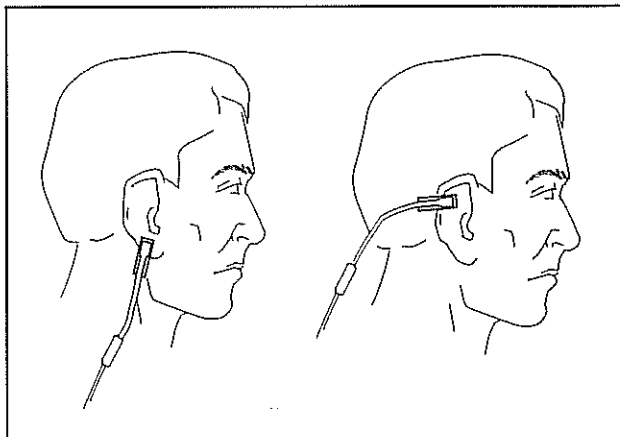

Place the sensor on the ear in either of the positions shown above. To prevent the sensor from slipping, use the clip on the cable to secure the cable to the patient's clothing.

OTHER SITES: Artificial fingernails and dark nail polish may cause interference. When it is impractical to remove the nail or polish, attach the Multi-Site Sensor directly proximal to the nail.

LIST OF AVAILABLE MULTI-SITE EQUIPMENT

- 513 Forehead Applicator and Headband
- 514 Earclip
- 516 Multi-Site Sensor Package
 - Sensor
 - Patient Cable
 - Forehead Applicator
 - Headband
 - Microfoam Tape (2 packs)
 - Ear Clip
 - Adhesive Dots (1 pack)
- 517 Multi-Site Sensor only
- 518 Patient Cable only
- 525 Double-Sided Adhesive Dots
- 526 Tape - Microfoam (4" strips, 14 per package)



Criticare Systems, Inc.
1 (800) 458-4615
20900 Swenson Dr., Suite 398
Waukesha, WI 53186